



2024

Product Data Guide

Truck, Bus & Trailer Tires

Innovative Tire Technology
Full Tire Life Cycle / ContiTread™
Digital Tire Monitoring Solutions

Continental is dedicated to pioneering technologies and services for sustainable and connected mobility of people and their goods. Founded in 1871, we offer intelligent, efficient, and affordable solutions for trucks, buses, and more.

2024 Product Data Guide

Truck, Bus and Trailer Tires to fit your needs.

As an international partner to the transport and logistics industry, we know the markets as well as we know the roads around the world. And we also know that ultimately, cost effectiveness is what matters.

But just like roads, no two operations are the same. That's why we developed Continental Truck Tires – the ideal solution to deliver your **Lowest Overall Driving Cost.**

As one of the largest automotive suppliers and tire manufacturers in the world, Continental develops pioneering technologies to make your fleet safer, more efficient, and more connected. With innovative tire technology and digital fleet solutions, Continental optimizes your tire management.

Count on Continental to recommend the best tires and solutions for your specific fleet needs.

IMPORTANT NOTE:

Product details are subject to change. If the information you are looking for is not in this data guide, please visit www.continental-truck.com or contact your local sales representative for the most up to date information.

Table of Contents

*Available in ContiTread™

OVERVIEW

Tire Availability Chart.....	04
Tire Comparison Chart.....	05
Application Chart.....	06
Vocation Reference Guide	07
Tire Product Overview	08
ContiTread™ Product Overview	14
Retread Availability Chart	16
Retread Comparison Chart.....	19

PRODUCT DATA

LONG HAUL APPLICATION 19

Truck Tire Product Overview	20
Conti EcoPlus HS3+.....	21
Conti Coach HA3	22
Conti HSL 3.....	23
Conti HDL 3 LTL*.....	24
HDL2	25
HDL2+	26
HDL2 Eco Plus*	27
HDL2+ Eco Plus	28
HDL2 DL+*.....	29
HDL2 DL Eco Plus	30
Conti EcoPlus HT3*.....	31
Conti HTL 3	32
HTL1*.....	33
HTL2 Eco Plus (17.5").....	34

ContiTread™ Retread Products 36

REGIONAL APPLICATION..... 42

Truck Tire Product Overview	43
Conti HSR 3*.....	45

HSR2	46
HSR2 SA	47
HTR2 (19.5").....	48
HDR2+*	49
HDW2*.....	50
Conti Scandinavia HD3*	51
Conti Hybrid HD3	52
HDR.....	53
Conti Hybrid HT3*.....	54
Conti LAR 3 (16").....	55
LSR1*(17.5").....	56
HTR2*(17.5").....	57
Conti HSR 5 (19.5")*	58
Conti Hybrid HS3 (19.5").....	59
Conti HDR 5 (19.5")*	60
Conti Hybrid HD3 (19.5")	61
Conti Scandinavia HD3 (19.5")	62
Conti Hybrid HT3 (19.5")	63
ContiTread™ Retread Products	65
URBAN APPLICATION..... 72	
Truck Tire Product Overview	73
Conti Urban HA3.....	74
Conti HAU 3 WT*	75
ContiTread™ Retread Products	76
CONSTRUCTION APPLICATION..... 78	
Truck Tire Product Overview	79
Conti HSC 3*.....	80
Conti HAC 3	81
Conti HDC 3*.....	82
HDC1 HT*.....	83
HTC	84

ContiTread™ Retread Products 85

OFF-ROAD APPLICATION 87

Truck Tire Product Overview	88
HCS*	89
HDO	90
Conti Terra HD3 (19.5").....	91
ContiTread™ Retreads.....	92

DIGITAL SOLUTIONS

ContiPressureCheck™	93
Truck & Trailer Solution (LIVE)	94
Standalone Trailer Solution (LIVE)	95
ContiConnect Yard	96
Digital Solutions Offerings	97

TABLES/CHARTS

Medium Truck Load/Inflation Tables.....	99
Load Limits at Various Speeds	103
Reading Tire Information	105
Definitions	108
Low Aspect Ratio Tires	109
Service Descriptions	110
Load Index Numbers	111
Tread Wear Conversion Table	112
Retread Casing Fitment Guide	113
Safety Warnings	114
Delivery Receipt (D9)	117
Warranty Information	118

CONTINENTAL HIGHLIGHTS

Conti 3G Casing.....	12	Digital Tire Monitoring Solutions	70
ContiLifeCycle™ Retread Stages	13	Conti360° Fleet Services	77
EPA SmartWay	40	ContiLink	119
TrukFix Road Service Program	41	Dealer Marketing Suite Page	120

Tire Availability Chart

Medium Radial Truck Tires

LOAD RANGE	A	B	C	D	E	F	G	H	J	L	M	N
PLY RATING	2	4	6	8	10	12	14	16	18	20	22	24





TIRES & SIZES Load Range & Tread Depth (32 ^{nds})	19.5" & SMALLER											22.5" & 24.5"											SUPER SINGLE & WIDEBASE																
	LT215/85R16	LT225/75R16	LT235/85R16	LT245/75R16	10R17.5	215/75R17.5	235/75R17.5	245/70R17.5	225/70R19.5	245/70R19.5	265/70R19.5	285/70R19.5	10R22.5	11R22.5	12R22.5	255/70R22.5	275/70R22.5	275/80R22.5	295/75R22.5	295/60R22.5	295/80R22.5	305/70R22.5	315/80R22.5	285/75R24.5	11R24.5	12R24.5	325/95R24 (tube type)	385/65R22.5	425/65R22.5	445/50R22.5	445/65R22.5								
STEER / ALL-POSITION	Conti EcoPlus HS3+																																						
	Conti EcoPlus HS3																		G/H-19	J-15																			
	Conti Coach HA3																							L-17															
	Conti HSL 3																			G/H-20																			
	Conti HSR 3																			G/H-23	H-23				H-23	H-23													
	HSR2																		G-20	G/H-23	H-23																		
	HSR2 SA																				H-18	J-18				L-19													
	HTR2																																				L-21	L-22	
	Conti Urban HA3																							L-23															
	Conti HAU 3 WT																								L-26														
	Conti HSC 3																								L-24	H-24	H-24												
	Conti HAC 3																																					L-22	L-24
HCS																																				J-40		L-27	
DRIVE	Conti HDL 3 LTL																																						
	HDL2+																																						
	HDL2																																						
	HDL2 Eco Plus																																						L-27
	HDL2+ Eco Plus																																						
	HDL2 DL+																																						
	HDL2 DL Eco Plus																																						
	HDR2+																																						
	HDR																																						
	HDW2																																						
	Conti Scandinavia HD3																																						
	Conti HDC 3																																						
HDC1 HT																																							
HDO																																							
TRAILER	Conti EcoPlus HT3																																						
	Conti HTL 3																																						
	HTL1																																						L-13
	Conti Hybrid HT3																																						
	HTC																																						
16" & 17.5"	Conti LAR 3	E-14	E-14	E-14	E-14																																		
	LSR1					H-17																																	
	HTR2 (17.5")						H-16	H-16																															
	HTL2 Eco Plus							H-15	J-13	J-13																													
19.5" TIRES	Conti HSR 5																																						
	Conti Hybrid HS3																																						
	Conti HDR 5																																						
	Conti Hybrid HD3																																						
	Conti Scandinavia HD3																																						
	Conti Hybrid HT3																																						
	Conti Terra HD3																																						

All tires are tubeless except where noted.

Truck Tire Comparison Chart

	Continental	MICHELIN	BRIDGESTONE	GOODYEAR
STEER/ALL-POSITION	Conti EcoPlus HS3+	X Line Energy Z, X Line Energy Z+	R213 Ecopia, R283 Ecopia	Endurance LHS
	Conti EcoPlus HS3 (295/60R22.5)	X Line Energy Z	-	-
	Conti Coach HA3	X Line Energy Z Coach	-	G670 RV MRT
	Conti HSL 3	X Multi Energy Z2	R283S Ecopia	Fuel Max RSA
	Conti HSR 3	XZE2	R250ED	Endurance RSA
	HSR2	XZE2	R250ED	Endurance RSA
	HSR2 SA	XZE2+, X Multiway XZE	R250 ED	G670 RV MRT
	HTR2	XFE	R244	G296 MSA
	Conti Urban HA3	X InCity Z	-	-
	Conti HAU 3 WT	XZUS2	M870	Endurance WHA
	Conti HSC 3	X Works Z	M853	G751 MSA
	Conti HAC 3	XZY3	M864	G296 MSA
	HCS	XZL, XZL+	L315	G278 MSD
DRIVE POSITION	HDL2+/HDL2	X Line Energy D+	M713 Ecopia	Fuel Max LHD 2
	HDL2 Eco Plus	X-One Line Energy D	Greatec M835A Ecopia	Fuel Max SSD
	HDL2+ Eco Plus (295/60R22.5)	X Multi D 295	M749	-
	HDL2 DL+	XDA5+	M726 ELA	-
	HDL2 DL Eco Plus	-	-	Endurance LHD
	Conti HDL 3 LTL	X Multi Energy D	M760 Ecopia	G572 1AD Fuel Max
	HDR2+	X Multi D	M770	G182 RSD
	HDR	X Multi D	M726	Fuel Max RTD
	HDW2	XDN2	W919	G182 RSD
	Conti Scandinavia HD3	XDS2	W919	UltraGrip RTD
	Conti HDC 3	X Works D	L320	Armor Max Pro Grade MSD
	HDC1 HT	X Works Grip D	M775	Armor Max ESD
HDO	XDY-EX2	L317	G741 MSD	
TRAILER	Conti EcoPlus HT3	X Line Energy T/T2	R123 Ecopia	Fuel Max LHT
	Conti HTL 3	X Line Energy T/T2	-	G316 LHT
	HTL1	X One Line Energy T2	Greatec R197 Ecopia	Fuel Max SST
	Conti Hybrid HT3	XTE	R196A, R250F	Endurance RST
	HTC	-	M840	-
16"	Conti LAR 3	XPS RIB	Duravis R238	Endurance RSA ULT
17.5"	HTL2 Eco Plus (17.5")	XTA2 Energy	R238	KMax T
	HTR2 (17.5")	X Multi T	R238	G114 LHT
	LSR1	XZA	-	G114 LHT
19.5"	Conti HSR 5	Agilis HD Z	R238	Fuel Max RSA ULT
	Conti Hybrid HS3	Agilis HD Z	R238	Fuel Max RSA ULT
	Conti HDR 5	XDS 2	M729F	Fuel Max RTD ULT
	Conti Hybrid HD3	XDS 2	M729F	Fuel Max RTD ULT
	Conti Scandinavia HD3	XDS 2	M704	-
	Conti Hybrid HT3	X Line Energy T	-	-
	Conti Terra HD3	-	-	-

Application Guide

	 LONG HAUL Our most fuel-efficient tires, designed for highway traffic over long distances with even wear. <ul style="list-style-type: none"> • Lowest fuel consumption • Maximum mileage performance • Comfortable ride 	 REGIONAL Flexible tires offering good fuel efficiency on the highway, with excellent durability for off-highway driving. <ul style="list-style-type: none"> • Excellent wear resistance • Optimal traction on diverse roads • All-weather suitability 	 URBAN Reinforced, durable tires that tackle the challenges of city traffic with ease. <ul style="list-style-type: none"> • High resistance to curb damage • Very high mileage • Handles rapid changes of city traffic 	 CONSTRUCTION Take on the tough terrain of job sites and varied road conditions with these durable, high traction tires. <ul style="list-style-type: none"> • High mileage on the road • Maximum equipment up-times • Resists damage off the road 	 OFF-ROAD Our most durable, highest traction tires that perform their best in extreme locations. <ul style="list-style-type: none"> • Maximum durability for toughest conditions • Great traction on the harshest terrain • High carrying capacity for heavy loads
STEER/ALL-POSITION	Conti EcoPlus HS3+		Conti Urban HA3		
	Conti EcoPlus HS3	HSR2		Conti HAU 3 WT	HCS
	Conti Coach HA3				Conti HSC 3
		HSR2 SA			Conti HAC 3
		Conti LAR 3 (16")			
		HTR2			
		Conti HSR 5 (19.5")			
		Conti HSL 3			
		Conti Hybrid HS3 (19.5")			
		LSR1 (17.5")			
DRIVE POSITION	HDL2	HDR2+		Conti HDC 3	HDO
	HDL2+	Conti Scandinavia HD3			
	HDL2 Eco Plus			Conti Terra HD3 (19.5")	
	HDL2 DL Eco Plus	HDW2		HDC1 HT	
	Conti HDL 3 LTL	HDR			
		Conti HDR 5 (19.5")			
		HDL2 DL+			
		Conti Hybrid HD3			
		HDL2+ Eco Plus			
		Conti Hybrid HD3 (19.5")			
TRAILER POSITION	Conti EcoPlus HT3	HTR2 (17.5")			
	Conti HTL 3			HTC	
	HTL1				
	HTL2 Eco Plus (17.5")				
	Conti Hybrid HT3				
	Conti Hybrid HT3 (19.5")				

Tires in the Steering axle position are also suitable for trailing axles on trucks and as all-position fitment where traction is not of paramount importance.

Products by Vocation

SEGMENT / VOCATION		STEER/ALL-POSITION	DRIVE POSITION	TRAILER POSITION	
GOODS	Car Carriers		Conti EcoPlus HS3	HDL2+ Eco Plus, Hybrid HD3 (19.5")	Conti Hybrid HT3, HSR2 SA
	General Freight (Long Haul)		Conti EcoPlus HS3+	Conti HDL 3 LTL, HDL2, HDL2+, HDL2 DL+, HDL2 DL Eco Plus, HDL2 Eco Plus	Conti EcoPlus HT3, Conti HTL 3, HTL1
	General Freight (Regional Haul)		HSR2, Conti HSR 3, Conti HSL 3	Conti HDL 3 LTL, HDR2+, HDR2 Eco Plus, HDL2 DL+, Scandinavia HD3, HDW2, Conti HSR 5 (19.5"), Conti HDR 5 (19.5")	Conti Hybrid HT3, Conti EcoPlus HT3, Conti HTL 3
	Local Pickup & Delivery Vehicles		Conti HSR 5 (19.5"), Conti LAR 3 (16"), HSR2, Conti HSR 3	Conti HSR 5 (19.5"), Conti HDR 5 (19.5"), HDR2+, HDL2 DL+	Conti Hybrid HT3, Conti EcoPlus HT3, Conti HTL 3
	Lease & Rental Vehicles		Conti EcoPlus HS3+, Conti HSL 3, HSR2, Conti HSR 3	HDL2 DL+, HDL2+, HDL2, HDL2 Eco Plus, HDR2+, HDW2, Scandinavia HD3	Conti Hybrid HT3, Conti EcoPlus HT3, Conti HTL 3, HTL1
	Refrigerated Trucks		Conti EcoPlus HS3+, Conti HSL 3, HSR2, Conti HSR 3	HDL2+, HDL2, HDL2 DL+, HDL2 DL Eco Plus, HDL2 Eco Plus, HDW2, Scandinavia HD3	Conti EcoPlus HT3, Conti HTL 3, Conti Hybrid HT3
	Beverage Haulers		HSR2, Conti HSR 3, Conti HSL 3, HTR2	HDR2+, HDL2 DL+, HDW2, Scandinavia HD3	Conti Hybrid HT3, HTL2 Eco Plus (17.5"), HTR2 (17.5")
	Household Movers		Conti EcoPlus HS3+, Conti HSL 3, HSR2, Conti HSR 3	HDL2+, HDL2, HDL2 DL+, HDL2 DL Eco Plus, HDR2+, HDR, HDW2, Scandinavia HD3	Conti EcoPlus HT3, Conti Hybrid HT3, HTL2 Eco Plus (17.5"), HTR2 (17.5")
	Tankers / Liquid Bulk Haulers		Conti EcoPlus HS3+, Conti HSL 3, Conti HSR 3, HSR2	HDL2+, HDL2, HDL2 Eco Plus, HDL2 DL+, HDR2+, HDW2	HSR2, Conti HSR 3, Conti EcoPlus HT3, HTL1, Conti Hybrid HT3
	Hazardous Material Haulers		Conti EcoPlus HS3+, Conti HSL 3, Conti HSR 3, HSR2	HDL2+, HDL2, HDL2 Eco Plus, HDL2 DL+	HSR2, Conti HSR 3, Conti EcoPlus HT3, HTL1, Conti Hybrid HT3
PEOPLE	Motor Coaches		Conti Coach HA3, HSR2 SA	Conti Coach HA3, HSR2 SA	-
	School Buses		HSR2, Conti HSR 3	HDR2+, HDW2	-
	City Buses		Conti Urban HA3	Conti Urban HA3	-
	RVs		Conti Coach HA3, HSR2 SA, Conti HSL 3	-	-
CONSTRUCTION	Construction Material Transport Vehicles		HSR2, Conti HSR 3, Conti HSC 3, Conti HAC 3, HTR2	HDR2, Conti HDC 3, Conti HSC 3	HSR2, Conti HSR 3, Conti HSC 3
	Utility Vehicles		HSR2, Conti HSR 3, Conti HSC 3, Conti HSL 3,	Conti HDR 5 (19.5"), HDR2+, Conti HAC 3, HTR2	HTR2, HSR2, Conti HSR 3, Hybrid HT3
	Emergency Vehicles		HTR2, Conti HSC 3, HSC1, HSR2, Conti HSR 3, HSR+, Conti HSL 3, HSR2 SA, HAU 3 WT, Conti HSR 5 (19.5")	HDR2+, HDW2, Scandinavia HD3, Conti HDR 5 (19.5")	-
	Waste & Sanitation Vehicles		Conti HAU 3 WT, Conti HSC 3	Conti HAU 3 WT, Conti HDC 3, HDR2+	-
	Agriculture, Feed & Livestock Transport Vehicles		HSR2, Conti HSR 3, Conti HSC 3	HDR2, Conti HDC 3, Conti HSC 3	HSR2, Conti HSR 3, Conti HSC 3
	Forestry & Lumber Vehicles		Conti HSC 3, HSR2, Conti HSR 3	HDC1 HT, HDO	Conti HSC 3, HSR2, Conti HSR 3
	Mining / Quarry Vehicles		HCS, Conti HSC 3, Conti HAC 3	Conti HDC 3, HDC1 HT, HCS, Conti Terra HD3 (19.5")	Conti HAC 3, Conti HSC 3, HSR2, Conti HSR 3
	Heavy Haul & Special Load Transport Vehicles		Conti HSL 3, Conti EcoPlus HS3+, HSR2, Conti HSR 3	HDL2+, HDL2, HDL2 DL+, HDR2+	Conti EcoPlus HT3, Hybrid HT3, HTL2 EcoPlus (17.5"), HTR2 (17.5")
	Cement Vehicles		Conti HAC 3, HTR2, Conti HSC 3, HCS	Conti HSC 3, Conti HDC 3, HDC1 HT, HDR2+	HTC, Conti HSC 3

Application Key:



PLEASE NOTE: The tires depicted in this chart are suggested as the primary products for each segment and are subject to change depending on application. Not every product in the Continental portfolio is represented. For more information, please visit www.continental-truck.com or contact your local sales representative for the most up to date information.

Steer/All-Position Product Overview

Legend:

			
3G Casing	SmartWay® Verified	Intelligent Tire	Retread Available

PRODUCT FEATURES ABOVE ONLY APPLY TO PRODUCTS IF THE MATCHING ICON IS DARKENED.



Conti EcoPlus HS3+



Page 21



Conti Coach HA3



Page 22



Conti HSL 3



Page 23



Conti HSR 3



Page 45



HSR2



Page 46



HSR2 SA



Page 47



HTR2



Page 48



Conti Urban HA3



Page 74



Conti HAU 3 WT



Page 75



Conti HSC 3



Page 80

16" Tire

17.5" Tire



Conti HAC 3



Page 81



HCS



Page 89



Conti LAR 3 (16")



Page 55



LSR1 (17.5")



Page 56

Drive Position

Product Overview

Legend:

 3G Casing	 SmartWay® Verified	 Intelligent Tire	 Retread Available
---	---	---	--

PRODUCT FEATURES ABOVE ONLY APPLY TO PRODUCTS IF THE MATCHING ICON IS DARKENED.



Conti HDL 3 LTL
   
 Page 24



HDL2
   
 Page 25



HDL2+
   
 Page 26



HDL2 Eco Plus
   
 Page 27



HDL2+ Eco Plus
   
 Page 28



HDL2 DL+
   
 Page 29



HDL2 DL Eco Plus
   
 Page 30



HDR2+
   
 Page 49



HDW2
   
 Page 50



Conti Scandinavia HD3
   
 Page 51



Conti Hybrid HD3
   
 Page 52



HDR
   
 Page 53



Conti HDC 3
   
 Page 82



HDC1 HT
   
 Page 83



HDO
   
 Page 90

Trailer Position Product Overview

Legend:

3G 3G Casing	 SmartWay® Verified	 Intelligent Tire	 Retread Available
------------------------	---	---	--

PRODUCT FEATURES ABOVE ONLY APPLY TO PRODUCTS IF THE MATCHING ICON IS DARKENED.



Conti HTL 3
3G   
Page 32



Conti EcoPlus HT3
3G   
Page 31



HTL1
3G   
Page 33



Conti Hybrid HT3
3G   
Page 54



HTC
3G   
Page 84

17.5" Tires



HTL2 Eco Plus (17.5")
3G   
Page 34



HTR2 (17.5")
3G   
Page 57

19.5" Tires



Product Overview

Legend:

3G 3G Casing	 SmartWay® Verified	 Intelligent Tire	 Retread Available
------------------------	---	---	--

PRODUCT FEATURES ABOVE ONLY APPLY TO PRODUCTS IF THE MATCHING ICON IS DARKENED.



Conti HSR 5
3G   
Page 58





Conti Hybrid HS3
3G   
Page 59



Conti HDR 5
3G   
Page 60





Conti Hybrid HD3
3G   
Page 61



Conti Scandinavia HD3
3G   
Page 62



Conti Hybrid HT3
3G   
Page 63



Conti Terra HD3
3G   
Page 91

3Gasing

A Next-Generation Solution for Easier Casing Management and Maximum Retreadability

Increased Belt Cord Angles

Belt features increased stiffness and improved penetration resistance. Innovative belt package designed to reduce heat and increase durability.

Increased Tread Volumes

Wider tread platform allows the casing to better support the tire's given load range. Tread features a wide cavity, with a standard retread width to provide a single platform for greater ease of retreading of 240-245mm treads.

Technologically Advanced Bead Core

Core designed for structural durability and extended product life. Core is made from a tear-resistant compound at steel cord edges.

Heat Dissipating Polymers

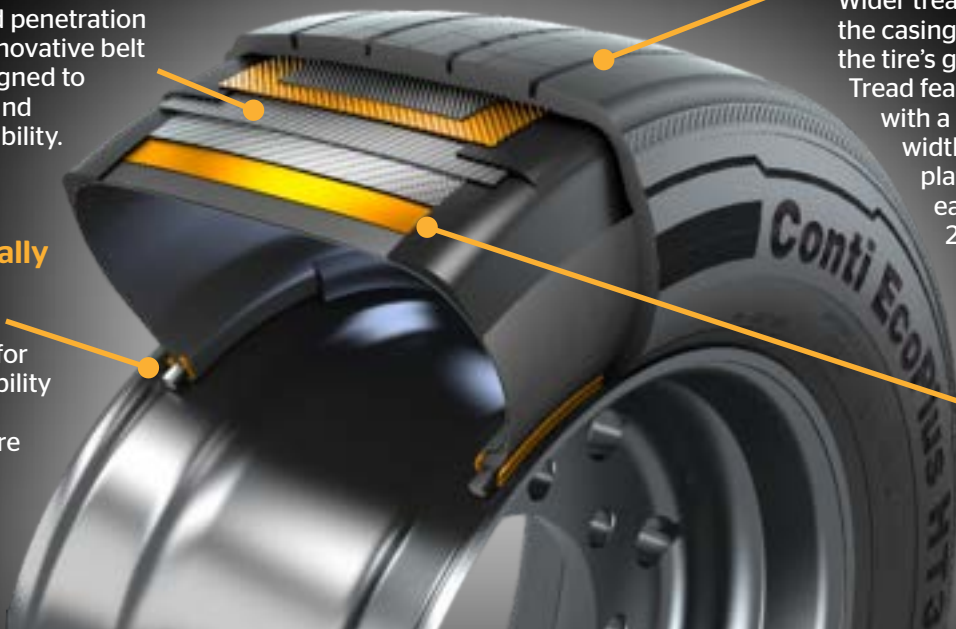

Fuel Savings



Increased Mileage



Improved Retreadability



Standardized Casing

These Continental Tires are Built on the Innovative 3G Casing:



Conti EcoPlus HS3+



Conti HSL 3



Conti HSR 3



Conti HSC 3



Conti HDL 3 LTL



HDL2



HDL2+



HDL2 DL+



HDL2 DL Eco Plus



HDR2+



HDW2



Conti Scandinavia HD3



Conti HDC 3



HDC1 HT



Conti EcoPlus HT3



Conti HTL 3



Continental Retread Solutions

ContiLifeCycle™ Retread Stages

Technology Driven for High-Quality Retreading

8 Process Control

Constant process and quality optimization by our globally connected retread specialists.

1 Inspection & Shearography

Thorough initial casing inspection using state-of-the-art technology.

2 Buffing

Precise buff contours and consistent under-tread thickness by computer controlled buffing.

7 Final Inspection

Detailed final inspection, ending with high pressure testing.

6 Curing

Ideal retread curing with precisely controlled time, temperature, vacuum and pressure.

3 Skiving & Repairs

Professional casing skiving and repairs, conducted by Continental trained operators.

5 Enveloping

Our modern enveloping technology enables an optimum curing process.

4 Tread Building

Optimum casing fitting, ensured by laser guided tread application.

To learn more, contact your Continental representative today!



Conti Tread™

Product Overview





Legend:

	
SmartWay® Verified	New Tire Available

All-Position

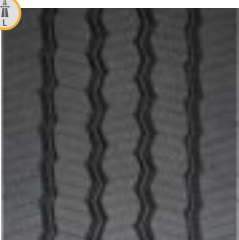
 Conti HSR 5 (19.5")  	 HSR 3  	 HSR - 18/32"  	 HSR - 16/32"  	 LSR1  
 HAU 3 WT  	 HSC 3  	 HSC - 18/32"  	 HCS  	

Drive Position

 HDL 3 LTL-R  	 HDL2 DL  	 HDL  	 HDL Eco Plus  	 HDL2 Eco Plus  
 Conti HDR 5 (19.5")  	 HDR2  	 HDR1  	 HDR1 Eco Plus  	











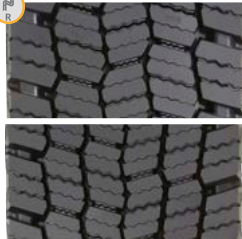
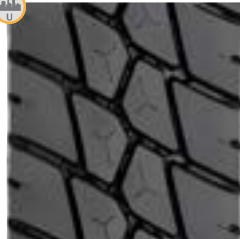

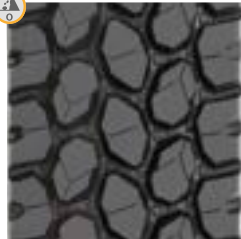
ContiTread™

Product Overview











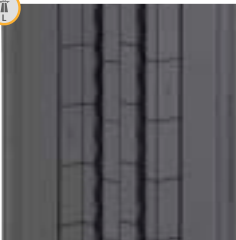

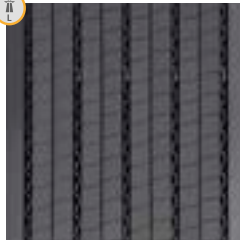

Legend:

	
SmartWay® Verified	New Tire Available

Drive Position (Continued)

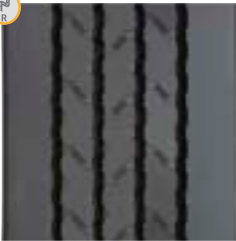
				
Scandinavia HD3  	HDW2  	HDU 3 WT  	HDC 3  	HDC1 HT  

Trailer Position

				
EcoPlus HT3  	HTL  	HTL1  	Hybrid HT3  	HTR2 SA  
				
HTR2  	HTC1  			

Conti Tread™ Retread Availability Chart

TREAD (MM)		160	170	180	185	188	190	195	200	205	210	215	220	225	230	235	240	
ALL-POSITION	HSR 5 (19.5")								16/32"		16/32"							
	HSR 3						20/32"		20/32"		20/32"		20/32"		20/32"		20/32"	
	HSR - 16/32"			16/32"				16/32"										
	HSR - 18/32"							18/32"				18/32"		18/32"		18/32"		
	LSR1	15/32"		15/32"		15/32"		15/32"		15/32"								
	HAU 3 WT										26/32"		26/32"		26/32"		26/32"	
	HSC 3										24/32"		24/32"		24/32"		24/32"	
	HSC											18/32"		18/32"		18/32"		
	HCS											32/32"		32/32"		32/32"		
DRIVE POSITION	HDL 3 LTL-R										22/32"		22/32"		22/32"		22/32"	
	HDL2 DL											28/32"		28/32"		28/32"		
	HDL - 13/32"											13/32"		13/32"		13/32"		
	HDL - 20/32"											20/32"		20/32"		20/32"		
	HDL - 26/32"											26/32"		26/32"		26/32"		
	HDL Eco Plus - 20/32"											20/32"		20/32"		20/32"		
	HDL Eco Plus - 26/32"											26/32"		26/32"		26/32"		
	HDL2 Eco Plus																	
	HDR 5 (19.5")								22/32"		22/32"		22/32"					
	HDR2 - 22/32"				22/32"				22/32"									
	HDR2 - 26/32"									26/32"		26/32"		26/32"		26/32"		26/32"
	HDR1 - 16/32"	16/32"	16/32"	16/32"				16/32"	16/32"			16/32"						
	HDR1 - 20/32"							20/32"	20/32"									
	HDR1 - 22/32"																22/32"	
	HDR1 - 26/32"											26/32"		26/32"		26/32"		26/32"
	HDR1 Eco Plus											22/32"		22/32"		22/32"		22/32"
	Scandinavia HD3											25/32"		25/32"		25/32"		25/32"
	HDW2											27/32"		27/32"		27/32"		27/32"
	HDU 3 WT											32/32"		32/32"		32/32"		32/32"
	HDC 3											28/32"		28/32"		28/32"		28/32"
HDC1 HT													32/32"		32/32"		32/32"	
TRAILER POSITION	EcoPlus HT3											13/32"		13/32"		13/32"		
	HTL								13/32"		13/32"		13/32"		13/32"		13/32"	
	HTL1																	
	Hybrid HT3								16/32"		16/32"		16/32"		16/32"		16/32"	
	HTR2 SA																16/32"	
	HTR2																	
HTC1																		

ContiTread™

Retread Availability Chart (Continued)

TREAD (MM)		245	250	255	260	270	280	290	320	340	350	360	370	380	390	400	410
ALL-POSITION	HSR 5 (19.5")																
	HSR 3																
	HSR - 16/32"																
	HSR - 18/32"	18/32"			18/32"												
	LSR1																
	HAU 3 WT		26/32"		26/32"	26/32"	26/32"										
	HSC 3																
	HSC																
	HCS	32/32"											32/32"		32/32"		
DRIVE POSITION	HDL 3 LTL-R																
	HDL2 DL	28/32"															
	HDL - 13/32"																
	HDL - 20/32"																
	HDL - 26/32"	26/32"															
	HDL Eco Plus - 20/32"	20/32"															
	HDL Eco Plus - 26/32"	26/32"															
	HDL2 Eco Plus															24/32"	24/32"
	HDR 5 (19.5")																
	HDR2 - 22/32"																
	HDR2 - 26/32"	26/32"															
	HDR1 - 16/32"																
	HDR1 - 20/32"																
	HDR1 - 22/32"																
	HDR1 - 26/32"	26/32"															
	HDR1 Eco Plus																
	Scandinavia HD3																
	HDW2	27/32"			27/32"												
	HDU 3 WT		32/32"		32/32"	32/32"	32/32"										
	HDC 3		28/32"														
HDC1 HT	32/32"																
TRAILER POSITION	EcoPlus HT3	13/32"															
	HTL																
	HTL1														13/32"	13/32"	
	Hybrid HT3																
	HTR2 SA		16/32"		16/32"	16/32"											
	HTR2								22/32"	22/32"	22/32"						
	HTC1									24/32"		24/32"			23/32"		

Conti Tread™ Retread Comparison Chart

	Conti Tread™	BANDAG	MICHELIN	GOODYEAR
ALL-POSITION	HSR 5 - 19.5"	BDR-AS	XDE M/S, XDC	G167
	HSR 3	UAP2, BDV	XZE2	G661 HSA
	HSR - 18	Ultra All Position	XZE	All Position 18, G661 HSA
	HSR - 16	FCR Rib	XZE	G159, G661 HSA
	LSR1	FCR Rib	XZA	G159
	HAU 3 WT	BRM, BRM3	XZUS	Endurance WHA, G686 G289 WHA
	HSC 3	BRM, BRX2	XZY3	G287 MSA
	HSC	BRX	XZY	G186 MSA
	HCS	BDY2	XZL, XZH	G177 Modified
DRIVE POSITION	HDL 3 LTL-R	B713, B760	X Multi Energy D	-
	HDL2 DL	MegaTrek	XDA HT	G328
	HDL - 26	Ultra Drive	XDHT	G362
	HDL - 20	FCR Drive, DR 5.3	XDHT	G362
	HDL - 13	BTT2	XDC LL	G362
	HDL Eco Plus - 26	B710 Fuel Tech	X Line Energy D	G572 LHD Fuel Max
	HDL Eco Plus - 20	FCR Drive	XDA 2 AT	Fuel Max LHD G505D
	HDL2 Eco Plus	B835 FuelTech	X One Line Energy D	G392 SSD Fuel Max
	HDR 5 - 19.5"	FCR Rib	XZA	G647 RSA
	HDR2 - 22	BDR-AS	MD XDN2	G167
	HDR2 - 26	Ultra Drive, BDR-HT3	X Multi D, XD4, XDN2	G182
	HDR1 - 16	BDLT	XDE M/S	G622 LT
	HDR1 - 20	BDL	XDE M/S	RDA
	HDR1 - 22	BDR-AS	XDE M/S, XDC	G167
	HDR1 - 26	Ultra Drive	XDN2	G338
	HDR1 Eco Plus	BDR-AS	-	G622
	Scandinavia HD3	-	XDS2	Endurance WTD, WinterTrac 2
	HDW2	BDR-W	XDS2	G622 RSD
	HDU 3 WT	BDM3	XDUS	Endurance WHD, G292 WHD
	HDC 3	BDY2, BDY1	XDY, XDY-1	G677 MSD
	HDC1 HT	BDY2	XDY-EX	G741 MSD
	TRAILER POSITION	Conti EcoPlus HT3	B123, B197 FuelTech, FCR T2	XTA-2, X Line Energy T, XT-1 AT
HTL		BTL, TR 4.1	XTA-1	G314, G159, LCT 11
HTL1		B135 FuelTech	X One Line Energy T & T2	G394 SST Fuel Max
Hybrid HT3		B123, B197 Fuel Tech, FCR T2	X Multi T SA, XTY SA	G619 RST
HTR2 SA		BTL-SA, ECL ST	XTE2 Widebase, XTA	G619 RST
HTR2		-	XZH, XZA Wide Base	G296 MSA
HTC1		BRM-WB	XZL, XZY3 and XZY Widebase	G296 MSA



High Removal Mileage // Low Rolling Resistance // Even Wear // Optimal Retreadability

Long Haul

For Long-Distance Highway Driving

Engineered for your application. Tires for Long Haul use are designed for straight line, on-highway driving, distributing freight from state to state across great distances. Tires are optimized for high removal miles and fuel efficiency.

IMPORTANT NOTE: Tire Products are now classified by route. Product details are subject to change, please visit our website or contact your local sales representative for the most up to date information.

			
3G Casing	SmartWay® Verified	Intelligent Tire	Retread Available

PRODUCT FEATURES ABOVE ONLY APPLY TO PRODUCTS IF THE MATCHING ICON IS DARKENED.

Long Haul

Truck Tire Product Overview



Conti EcoPlus HS3+
   



Conti Coach HA3
   



Conti HSL 3
   



Conti HDL 3 LTL
   



HDL2
   



HDL2+
   



HDL2 Eco Plus
   



HDL2+ Eco Plus
   



HDL2 DL+
   



HDL2 DL Eco Plus
   

17.5" Tires



Conti HTL 3
   



Conti EcoPlus HT3
   



HTL1
   



HTL2 Eco Plus (17.5")
   

3G Casing	SmartWay® Verified	Intelligent Tire	Retread Available

PRODUCT FEATURES ABOVE ONLY APPLY TO PRODUCTS IF THE MATCHING ICON IS DARKENED.

Conti EcoPlus HS3+

Fuel-Efficient, Long Haul Steer

GOODS PEOPLE CONSTRUCTION

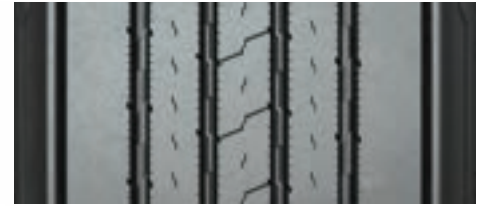

*TREAD B: Conti EcoPlus HS3

PRODUCT DATA



TIRE SIZE	LOAD RANGE	ARTICLE NUMBER	TREAD DEPTH (32nds)	MAX SPEED (MPH)	STATIC LOADED RADIUS		OVERALL INFLATED DIAMETER		OVERALL INFLATED WIDTH		LOADED SECTION WIDTH		APPROVED RIM(S)	MINIMUM DUAL SPACING		REVS PER UNIT		TIRE WEIGHT		MAX. LOAD @ INFLATION	
					IN	MM	IN	MM	IN	MM	IN	MM		IN	MM	MI	KM	LB	KG	SINGLE	DUAL
11R22.5	G	05126130000 #05653300000	19	75	19.5	495	41.8	1062	11.7	296	13.1	331	8.25, 7.50	12.5	318	495	308	119	54	6175, 105 (2800, 720)	5840, 105 (2650, 720)
11R22.5	H	05126140000 #05653310000	19	75	19.5	495	41.8	1062	11.7	296	13.1	331	8.25, 7.50	12.5	318	495	308	121	55	6610, 120 (3000, 830)	6005, 120 (2725, 830)
295/60R22.5 (Tread B)	J	05111670000 #05652270000	15	75	17.1	434	37.0	940	11.5	292	12.0	304	9.00, 9.75	12.9	329	574	356	110	50	7390, 130 (3350, 900)	6780, 130 (3075, 900)
295/75R22.5	G	05126150000 #05653320000	19	75	18.7	475	39.9	1013	11.4	290	12.3	312	8.25, 9.00	12.5	318	519	322	114	52	6175, 110 (2800, 760)	5675, 110 (2575, 760)
295/75R22.5	H	05126160000 #05653330000	19	75	18.7	475	39.9	1013	11.4	290	12.3	312	8.25, 9.00	12.5	318	519	322	117	53	7160, 123 (3250, 850)	6610, 123 (3000, 850)
11R24.5	H	05126170000 #05653340000	19	75	20.4	518	43.8	1113	11.7	297	13.1	333	8.25, 7.50	12.5	318	473	294	130	59	7160, 120 (3250, 830)	6610, 120 (3000, 830)
285/75R24.5	H	05126180000 #05653350000	19	75	19.3	490	41.5	1054	11.4	289	12.9	328	8.25	12.5	318	499	310	122	55	6780, 120 (3075, 830)	6175, 120 (2800, 830)

TUBELESS TIRES ON 15 DEGREE DROP CENTER RIMS

Note - Rim listed first is the measuring rim. # = Intelligent Tire Article #. Minimum Dual Spacing calculated without chains. 295/60R22.5 size designated for car carrier application. # - Exceeding the lawful speed limit is neither recommended nor endorsed. Overall widths will change 0.1 inch (2.5 mm) for each 1/4 inch change in rim width. Minimum dual spacing should be adjusted accordingly. Continental Tire the Americas, LLC reserves the right to change product specifications at any time without notice or obligations. Please consult rim manufacturers load and inflation limits. Never exceed rim manufacturers limits without permission of component manufacturer.

Features & Benefits



Conti EcoPlus HS3+ has a **27% improvement in removal mileage with even wear** over its predecessor, Conti EcoPlus HS3.



Tread profile reduces sensitivity to road surface, fleet, and vehicle variations allowing for improved performance throughout tire life.



10% improvement in de-coupler durability, an essential benefit for products in the steer/ all-position category to extend tire life.



Improved footprint shape delivers significant wear improvements for increased removal miles.

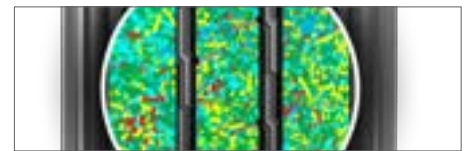

Technologically advanced cap/base compounds provide improved cut and tear resistance for increased mileage.



Built on the innovative **Conti 3G Casing** for maximum retreadability.

Applications: Long Haul

3G Casing	SmartWay* Verified	Intelligent Tire	Retread Available

PRODUCT FEATURES ABOVE ONLY APPLY TO PRODUCTS IF THE MATCHING ICON IS DARKENED.

Conti Coach HA3

Intelligent All-Position Long Haul Coach

● GOODS ● PEOPLE ● CONSTRUCTION



PRODUCT DATA

TIRE SIZE	LOAD RANGE	ARTICLE NUMBER	TREAD DEPTH (32nds)	MAX SPEED (MPH)	STATIC LOADED RADIUS		OVERALL INFLATED DIAMETER		OVERALL INFLATED WIDTH		LOADED SECTION WIDTH		APPROVED RIM(S)	MINIMUM DUAL SPACING		REVS PER UNIT		TIRE WEIGHT		MAX. LOAD @ INFLATION	
					IN	MM	IN	MM	IN	MM	IN	MM		IN	MM	MI	KM	LB	KG	LBS, PSI (KG, KPa)	LBS, PSI (KG, KPa)
315/80R22.5	L	05651710000	17	75	19.7	501	42.4	1077	12.4	315	13.6	345	9.00, 8.25*	13.8	351	488	303	148	67	9090, 130 (4125, 900)	8270, 130 (3750, 900)

TUBELESS TIRES ON 15 DEGREE DROP CENTER RIMS

*315/80R22.5 tires used on 8.25" rims are restricted to a maximum of 7610 lbs at 120 psi.

Note - Rim listed first is the measuring rim. # = Intelligent Tire Article #. Minimum Dual Spacing calculated without chains. These specifications subject to change without notice. # - Exceeding the lawful speed limit is neither recommended nor endorsed. Overall widths will change 0.1 inch (2.5 mm) for each 1/4 inch change in rim width. Minimum dual spacing should be adjusted accordingly. Continental Tire the Americas, LLC reserves the right to change product specifications at any time without notice or obligations. Please consult rim manufacturers load and inflation limits. Never exceed rim manufacturers limits without permission of component manufacturer.

Features & Benefits



Extra load-carrying capacity with a specially reinforced **Stable Bead Technology**.



Durable casing for premium retreadability and enhanced mileage.

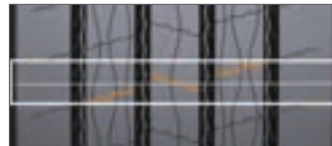

Noise-Reducing Tread Design for serene and comfortable travel.

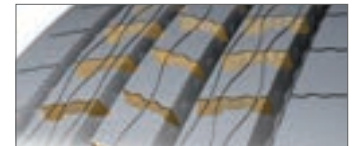

A lifetime of all-weather traction with **interlocking 3D sipes**.

sensor CONNECT Continental's Intelligent Tire

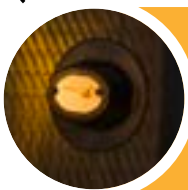

- Equipped with TPMS Sensor for accurate, real-time tire pressure and temperature readings.
- Sensor warranted for 5 Years to minimize disruptions.
- Sensor provides true casing temperature allowing preventive actions that make your tire last longer.
- Avoids valve damage and air leaks by mounting on the inner liner.

Learn more at www.continental-truck.com. See warranty policy for details.

Applications: Long haul, over the highway steering and all-position use, for coach and large RV use.

			
3G Casing	SmartWay® Verified	Intelligent Tire	Retread Available

PRODUCT FEATURES ABOVE ONLY APPLY TO PRODUCTS IF THE MATCHING ICON IS DARKENED.

Conti HSL 3

Fuel-Efficient, Super Regional Steer

 GOODS  PEOPLE  CONSTRUCTION



PRODUCT DATA



TIRE SIZE	LOAD RANGE	ARTICLE NUMBER	TREAD DEPTH (32nds)	MAX SPEED (MPH)	STATIC LOADED RADIUS		OVERALL INFLATED DIAMETER		OVERALL INFLATED WIDTH		LOADED SECTION WIDTH		APPROVED RIM(S)	MINIMUM DUAL SPACING		REVS PER UNIT		TIRE WEIGHT		MAX. LOAD @ INFLATION	
					IN	MM	IN	MM	IN	MM	IN	MM		IN	MM	MI	KM	LB	KG	LBS, PSI (KG, KPa)	LBS, PSI (KG, KPa)
11R22.5	H	05111570000 #05652660000 #	20	75	19.5	495	41.6	1056	11.7	297	13.1	331	8.25, 7.50	12.5	318	498	309	120	54	6610, 120 (3000, 830)	6005, 120 (2725, 830)
295/75R22.5	G	05111580000 #05652670000 #	20	75	18.7	474	40.0	1017	11.5	292	12.3	313	8.25, 9.00	12.5	318	517	321	111	50	6175, 110 (2800, 760)	5675, 110 (2575, 760)
295/75R22.5	H	05111590000 #05652680000 #	20	75	18.7	474	40.0	1017	11.5	292	12.3	313	8.25, 9.00	12.5	318	517	321	114	52	7160, 123 (3250, 850)	6610, 123 (3000, 850)

TUBELESS TIRES ON 15 DEGREE DROP CENTER RIMS

PLEASE NOTE: THIS PRODUCT WAS PREVIOUSLY NAMED CONTI HYBRID HS3.

Note - Rim listed first is the measuring rim. # = Intelligent Tire Article #. Minimum Dual Spacing calculated without chains. # - Exceeding the lawful speed limit is neither recommended nor endorsed. Overall widths will change 0.1 inch (2.5 mm) for each 1/4 inch change in rim width. Minimum dual spacing should be adjusted accordingly. Continental Tire the Americas, LLC reserves the right to change product specifications at any time without notice or obligations. Please consult rim manufacturers load and inflation limits. Never exceed rim manufacturers limits without permission of component manufacturer.

Features & Benefits

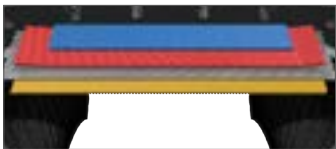

Increased stiffness in the **belt package** promotes smooth, even tread wear.

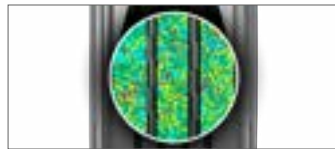

Advanced tread compounding delivers long removal mileage and low rolling resistance.



Fuel Saving Edge technology designed to increase fuel efficiency and application flexibility.



Built on the **Conti 3G Casing** for maximum retreadability.

Applications: Over the road super regional steer and all position use.

 3G Casing	 SmartWay® Verified	 Intelligent Tire	 Retread Available
---	---	---	--

PRODUCT FEATURES ABOVE ONLY APPLY TO PRODUCTS IF THE MATCHING ICON IS DARKENED.

Conti HDL 3 LTL

Heavy Haul, Single Axle, Long Haul Drive

GOODS PEOPLE CONSTRUCTION



PRODUCT DATA

TIRE SIZE	LOAD RANGE	ARTICLE NUMBER	TREAD DEPTH (32nds)	MAX SPEED (MPH)	STATIC LOADED RADIUS		OVERALL INFLATED DIAMETER		OVERALL INFLATED WIDTH		LOADED SECTION WIDTH		APPROVED RIM(S)	MINIMUM DUAL SPACING		REVS PER UNIT		TIRE WEIGHT		MAX. LOAD @ INFLATION	
					IN	MM	IN	MM	IN	MM	IN	MM		IN	MM	IN	MM	MI	KM	LB	KG
11R22.5	G	05211540000 #05653260000#	24	75	19.7	500	41.1	1061	11.6	294	12.6	320	8.25, 7.50	12.5	318	495	308	128	58	6175, 105 (2800, 720)	5840, 105 (2650, 720)
295/75R22.5	G	05211550000 #05653210000#	24	75	19.4	491	40.4	1025	11.7	297	12.7	322	8.25, 9.00	12.5	318	513	319	119	54	6175, 110 (2800, 760)	5675, 110 (2575, 760)
295/75R22.5	H	05212180000 #05653210000#	24	75	19.4	491	40.4	1025	11.7	297	12.7	322	8.25, 9.00	12.5	318	512	319	124	54	6610, 120 (3000, 760)	6005, 120 (2725, 760)
11R24.5	H	05211560000 #05653270000#	24	75	20.6	524	43.8	1112	11.6	295	12.7	322	8.25, 7.50	12.5	318	473	294	139	63	7160, 120 (3250, 830)	6610, 120 (3000, 830)

TUBELESS TIRES ON 15 DEGREE DROP CENTER RIMS

Note - Rim listed first is the measuring rim. # = Intelligent Tire Article #. Minimum Dual Spacing calculated without chains. # - Exceeding the lawful speed limit is neither recommended nor endorsed. Overall widths will change 0.1 inch (2.5 mm) for each 1/4 inch change in rim width. Minimum dual spacing should be adjusted accordingly. Continental Tire the Americas, LLC reserves the right to change product specifications at any time without notice or obligations. Please consult rim manufacturers load and inflation limits. Never exceed rim manufacturers limits without permission of component manufacturer.

Features & Benefits

<p>3-D matrix sipes provide superior traction and even wear.</p>			<p>Maximum stone ejection due to superior groove geometry.</p>
<p>Maximum fuel efficiency and high removal miles from advanced tread compounding.</p>	<p>Resists irregular wear caused from high-torque single drive position, including heel-toe wear, thanks to rigid tread blocks that effectively control movement.</p>	<p>Built on the innovative Conti 3G Casing for maximum retreadability.</p>	

 This product is 3PMSF Certified.

 This product is Mud + Snow Certified.

Applications: Long haul, over the highway, high torque, & single axle drive position.

			
3G Casing	SmartWay® Verified	Intelligent Tire	Retread Available

PRODUCT FEATURES ABOVE ONLY APPLY TO PRODUCTS IF THE MATCHING ICON IS DARKENED.

HDL2

Fuel-Efficient, Long Haul Drive

GOODS PEOPLE CONSTRUCTION



PRODUCT DATA

TIRE SIZE	LOAD RANGE	ARTICLE NUMBER	TREAD DEPTH (32nds)	MAX SPEED (MPH)	STATIC LOADED RADIUS		OVERALL INFLATED DIAMETER		OVERALL INFLATED WIDTH		LOADED SECTION WIDTH		APPROVED RIM(S)	MINIMUM DUAL SPACING		REVS PER UNIT		TIRE WEIGHT		MAX. LOAD @ INFLATION	
					IN	MM	IN	MM	IN	MM	IN	MM		IN	MM	MI	KM	LB	KG	LBS, PSI (KG, KPa)	LBS, PSI (KG, KPa)
11R22.5	G	05211220000 # 05651770000 #	26	75	19.6	499	42.0	1066	11.7	296	13.1	331	8.25, 7.50	12.5	318	493	306	125	57	6175, 105 (2800, 720)	5840, 105 (2650, 720)
11R22.5	H	05211230000 # 05652990000 #	26	75	19.6	499	42.0	1066	11.7	296	13.1	331	8.25, 7.50	12.5	318	493	306	128	58	6610, 120 (3000, 830)	6005, 120 (2725, 830)
11R24.5	G	05211240000	26	75	20.5	521	44.0	1118	11.7	296	13.1	331	8.25, 7.50	12.5	318	470	292	134	61	6610, 105 (3000, 720)	6005, 105 (2725, 720)

TUBELESS TIRES ON 15 DEGREE DROP CENTER RIMS

Note - Rim listed first is the measuring rim. # = Intelligent Tire Article #. Minimum Dual Spacing calculated without chains. # - Exceeding the lawful speed limit is neither recommended nor endorsed. Overall widths will change 0.1 inch (2.5 mm) for each 1/4 inch change in rim width. Minimum dual spacing should be adjusted accordingly. Continental Tire the Americas, LLC. reserves the right to change product specifications at any time without notice or obligations. Please consult rim manufacturers load and inflation limits. Never exceed rim manufacturers limits without permission of component manufacturer.

Features & Benefits

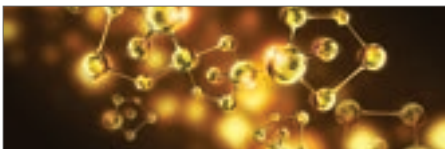

Advanced tread compounding for maximum fuel efficiency.

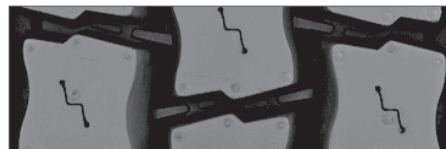

Innovative groove geometry minimizes stone retention.



Built on the Conti 3G Casing for maximum retreadability.

Applications: Long haul over the road drive positions.

			
3G Casing	SmartWay® Verified	Intelligent Tire	Retread Available

PRODUCT FEATURES ABOVE ONLY APPLY TO PRODUCTS IF THE MATCHING ICON IS DARKENED.

HDL2+

Fuel-Efficient, Long Haul Drive

GOODS PEOPLE CONSTRUCTION



PRODUCT DATA



TIRE SIZE	LOAD RANGE	ARTICLE NUMBER	TREAD DEPTH (32nds)	MAX SPEED (MPH)	STATIC LOADED RADIUS		OVERALL INFLATED DIAMETER		OVERALL INFLATED WIDTH		LOADED SECTION WIDTH		APPROVED RIMS)	MINIMUM DUAL SPACING		REVS PER UNIT		TIRE WEIGHT		MAX. LOAD @ INFLATION	
					IN	MM	IN	MM	IN	MM	IN	MM		IN	MM	MI	KM	LB	KG	LBS, PSI (KG, KPa)	LBS, PSI (KG, KPa)
					SINGLE		DUAL														
295/75R22.5	G	05211950000 # 05653940000 #	26	75	18.9	481	40.5	1029	11.5	292	12.9	328	8.25, 9.00	12.5	318	511	318	120	54	6175, 110 (2800, 760)	5675, 110 (2575, 760)
295/75R22.5	H	05211960000 # 05653930000 #	26	75	18.9	481	40.5	1029	11.5	292	12.9	328	8.25, 9.00	12.5	318	511	318	122	55	6610, 120 (3000, 830)	6005, 120 (2725, 830)

TUBELESS TIRES ON 15 DEGREE DROP CENTER RIMS

Note - Rim listed first is the measuring rim. # = Intelligent Tire Article #. Minimum Dual Spacing calculated without chains. # - Exceeding the lawful speed limit is neither recommended nor endorsed. Overall widths will change 0.1 inch (2.5 mm) for each 1/4 inch change in rim width. Minimum dual spacing should be adjusted accordingly. Continental Tire the Americas, LLC. reserves the right to change product specifications at any time without notice or obligations. Please consult rim manufacturers load and inflation limits. Never exceed rim manufacturers limits without permission of component manufacturer.

Features & Benefits

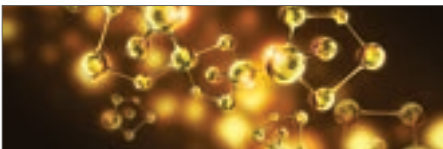

Advanced tread compounding for maximum fuel efficiency.

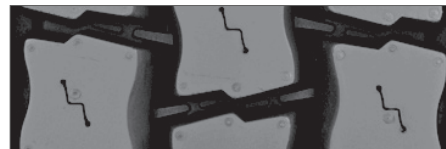

innovative groove geometry minimizes stone retention.



Built on the **Conti 3G Casing** for maximum retreadability.

Applications: Long haul over the road drive positions.

			
3G Casing	SmartWay® Verified	Intelligent Tire	Retread Available





PRODUCT FEATURES ABOVE ONLY APPLY TO PRODUCTS IF THE MATCHING ICON IS DARKENED.

HDL2 Eco Plus

Fuel-Efficient, Super Single Drive

 GOODS  PEOPLE  CONSTRUCTION



PRODUCT DATA																					
TIRE SIZE	LOAD RANGE	ARTICLE NUMBER	TREAD DEPTH (32nds)	MAX SPEED (MPH)	STATIC LOADED RADIUS		OVERALL INFLATED DIAMETER		OVERALL INFLATED WIDTH		LOADED SECTION WIDTH		APPROVED RIMS)	MINIMUM DUAL SPACING		REVS PER UNIT		TIRE WEIGHT		MAX. LOAD @ INFLATION	
					IN	MM	IN	MM	IN	MM	IN	MM		IN	MM	IN	MM	MI	KM	LB	KG
445/50R22.5	L	05210130000 # 05652840000 #	27	75	18.8	478	40.4	1027	17.5	445	19.2	488	14.00	N/A	N/A	512	318	200	91	10200,120 (4625, 830)	N/A

TUBELESS TIRES ON 15 DEGREE DROP CENTER RIMS

Note - Rim listed first is the measuring rim. # = Intelligent Tire Article #. Minimum Dual Spacing calculated without chains. # - Exceeding the lawful speed limit is neither recommended nor endorsed. Overall widths will change 0.1 inch (2.5 mm) for each 1/4 inch change in rim width. Minimum dual spacing should be adjusted accordingly. Continental Tire the Americas, LLC reserves the right to change product specifications at any time without notice or obligations. Please consult rim manufacturers load and inflation limits. Never exceed rim manufacturers limits without permission of component manufacturer.

Features & Benefits

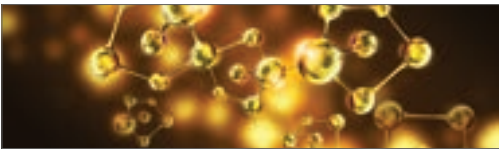

Advanced tread compound with super single weight reduction provides lower rolling resistance.



Features 27/32" tread depth, an **evolving sipe tread design** and closed shoulder.

Groove geometry designed with stress reduction elements to separate forces and reduce premature wear.

3-dimensional center sipes increase groove strength for longevity, while allowing more tread block flexibility.

Applications: Long haul, over the highway drive position.

 3G Casing	 SmartWay® Verified	 Intelligent Tire	 Retread Available
---	---	---	--

PRODUCT FEATURES ABOVE ONLY APPLY TO PRODUCTS IF THE MATCHING ICON IS DARKENED.

HDL2+ Eco Plus

Fuel-Efficient, Long Haul Drive for Car Carriers

GOODS PEOPLE CONSTRUCTION



PRODUCT DATA

TIRE SIZE	LOAD RANGE	ARTICLE NUMBER	TREAD DEPTH (32nds)	MAX SPEED (MPH)	STATIC LOADED RADIUS		OVERALL INFLATED DIAMETER		OVERALL INFLATED WIDTH		LOADED SECTION WIDTH		APPROVED RIM(S)	MINIMUM DUAL SPACING		REVS PER UNIT		TIRE WEIGHT		MAX. LOAD @ INFLATION	
					IN	MM	IN	MM	IN	MM	IN	MM		IN	MM	MI	KM	LB	KG	LBS, PSI (KG, KPa)	LBS, PSI (KG, KPa)
295/60R22.5	J	05211410000 # 05652270000 #	24	75	17.1	434	37.0	940	11.5	292	11.9	302	9.00, 9.75	12.9	328	559	348	118	54	7390, 130 (3350, 900)	6780, 130 (3075, 900)

TUBELESS TIRES ON 15 DEGREE DROP CENTER RIMS

Note - Rim listed first is the measuring rim. # = Intelligent Tire. Minimum Dual Spacing calculated without chains. # - Exceeding the lawful speed limit is neither recommended nor endorsed. Overall widths will change 0.1 inch (2.5 mm) for each 1/4 inch change in rim width. Minimum dual spacing should be adjusted accordingly. Continental Tire the Americas, LLC reserves the right to change product specifications at any time without notice or obligations. Please consult rim manufacturers load and inflation limits. Never exceed rim manufacturers limits without permission of component manufacturer.

Features & Benefits



Advanced tread compound provides extended original mileage and improved rolling resistance.



Closed shoulder tread design provides even tread wear while still providing excellent traction.

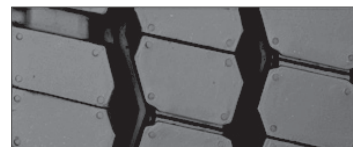

Patented innovative groove technology leads to minimal stone retention, extending casing life.



Offers large capacity and car carrier trucks the ability to **carry more weight without sacrificing vehicle height.**

Applications: Long haul and over the highway drive, for large capacity trucks or car carriers.

			
3G Casing	SmartWay® Verified	Intelligent Tire	Retread Available

PRODUCT FEATURES ABOVE ONLY APPLY TO PRODUCTS IF THE MATCHING ICON IS DARKENED.

HDL2 DL+

Long Haul Drive, Deep Lug

GOODS PEOPLE CONSTRUCTION



PRODUCT DATA

TIRE SIZE	LOAD RANGE	ARTICLE NUMBER	TREAD DEPTH (32nds)	MAX SPEED (MPH)	STATIC LOADED RADIUS		OVERALL INFLATED DIAMETER		OVERALL INFLATED WIDTH		LOADED SECTION WIDTH		APPROVED RIM(S)	MINIMUM DUAL SPACING		REVS PER UNIT		TIRE WEIGHT		MAX. LOAD @ INFLATION	
					IN	MM	IN	MM	IN	MM	IN	MM		IN	MM	MI	KM	LB	KG	SINGLE	DUAL
					LBS, PSI (KG, KPa)	LBS, PSI (KG, KPa)															
11R22.5	G	05211670000 #05653440000#	32	75	19.9	504	42.2	1071	11.6	294	13.0	329	8.25, 7.50	12.5	318	491	305	131	59	6175, 105 (2800, 720)	5840, 105 (2650, 720)
11R22.5	H	05211680000 #05653450000#	32	75	19.9	504	42.2	1071	11.6	294	13.0	329	8.25, 7.50	12.5	318	491	305	134	61	6610, 120 (3000, 830)	6005, 120 (2725, 830)
295/75R22.5	G	05211690000 #05653460000#	32	75	19.1	485	40.8	1036	11.4	290	12.7	323	8.25, 9.00	12.5	318	507	315	126	57	6175, 110 (2800, 760)	5675, 110 (2575, 760)
11R24.5	H	05211720000 #05653480000#	32	75	20.7	526	44.2	1122	11.6	295	13.0	330	8.25, 7.50	12.5	318	468	291	143	65	7160, 120 (3250, 830)	6610, 120 (3000, 830)
285/75R24.5	G	05211730000 #05653490000#	32	75	19.7	501	42.2	1072	11.4	290	12.6	321	8.25	12.5	318	491	305	131	60	6175, 110 (2800, 760)	5675, 110 (2575, 760)

TUBELESS TIRES ON 15 DEGREE DROP CENTER RIMS

Note - Rim listed first is the measuring rim. # = Intelligent Tire Article #. Minimum Dual Spacing calculated without chains. # - Exceeding the lawful speed limit is neither recommended nor endorsed. Overall widths will change 0.1 inch (2.5 mm) for each 1/4 inch change in rim width. Minimum dual spacing should be adjusted accordingly. Continental Tire the Americas, LLC reserves the right to change product specifications at any time without notice or obligations. Please consult rim manufacturers load and inflation limits. Never exceed rim manufacturers limits without permission of component manufacturer.

Features & Benefits

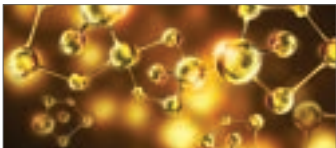

New tread cap/base compounds provide **improved wear performance** extending original tire life.



32/32" tread depth provides high mileage and low cost per mile.



Patented innovative groove technology leads to minimal stone retention, extending casing life.



Built on the **Conti 3G Casing** for maximum retreadability.

Applications: Long haul, over the highway drive position.

 3G Casing	 SmartWay® Verified	 Intelligent Tire	 Retread Available
---	---	---	--

PRODUCT FEATURES ABOVE ONLY APPLY TO PRODUCTS IF THE MATCHING ICON IS DARKENED.

HDL2 DL Eco Plus

Fuel-Efficient, Long Haul Drive, Deep Lug

 GOODS  PEOPLE  CONSTRUCTION



PRODUCT DATA



TIRE SIZE	LOAD RANGE	ARTICLE NUMBER	TREAD DEPTH (32nds)	MAX SPEED (MPH)	STATIC LOADED RADIUS		OVERALL INFLATED DIAMETER		OVERALL INFLATED WIDTH		LOADED SECTION WIDTH		APPROVED RIM(S)	MINIMUM DUAL SPACING		REVS PER UNIT		TIRE WEIGHT		MAX. LOAD @ INFLATION	
					IN	MM	IN	MM	IN	MM	IN	MM		IN	MM	MI	KM	LB	KG	LBS, PSI (KG, KPa)	LBS, PSI (KG, KPa)
11R22.5	G	05211100000 # 05651850000	32	75	19.7	500	42.2	1071	11.6	294	13.0	329	8.25, 7.50	12.5	318	491	305	132	60	6175, 105 (2800, 720)	5840, 105 (2650, 720)
295/75R22.5	G	05211520000	32	75	19.1	485	40.8	1036	11.4	289	12.7	323	8.25, 9.00	12.5	318	507	315	126	57	6175, 110 (2800, 760)	5675, 110 (2575, 760)

TUBELESS TIRES ON 15 DEGREE DROP CENTER RIMS

Note - Rim listed first is the measuring rim. # = Intelligent Tire Article #. Minimum Dual Spacing calculated without chains. # - Exceeding the lawful speed limit is neither recommended nor endorsed. Overall widths will change 0.1 inch (2.5 mm) for each 1/4 inch change in rim width. Minimum dual spacing should be adjusted accordingly. Continental Tire the Americas, LLC reserves the right to change product specifications at any time without notice or obligations. Please consult rim manufacturers load and inflation limits. Never exceed rim manufacturers limits without permission of component manufacturer.

Features & Benefits



Advanced tread compounding provides this Eco Plus version with 33% less rolling resistance than the original HDL2 DL.



32/32" tread depth provides high mileage and low cost per mile.



Patented innovative groove technology leads to minimal stone retention, extending casing life.

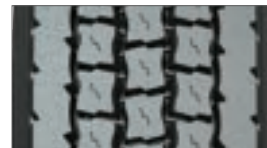

Minimized wear and excellent traction over the life of the tire, through a **wide, closed shoulder tread and numerous tread blocks** with multiple grip edges.



Built on the **Conti 3G Casing** for maximum retreadability.

Applications: Long haul, over the highway drive position.

			
3G Casing	SmartWay® Verified	Intelligent Tire	Retread Available

PRODUCT FEATURES ABOVE ONLY APPLY TO PRODUCTS IF THE MATCHING ICON IS DARKENED.

Conti EcoPlus HT3

Fuel-Efficient, Long Haul Trailer

 GOODS  PEOPLE  CONSTRUCTION



PRODUCT DATA

TIRE SIZE	LOAD RANGE	ARTICLE NUMBER	TREAD DEPTH (32nds)	MAX SPEED (MPH)	STATIC LOADED RADIUS		OVERALL INFLATED DIAMETER		OVERALL INFLATED WIDTH		LOADED SECTION WIDTH		APPROVED RIM(S)	MINIMUM DUAL SPACING		REVS PER UNIT		TIRE WEIGHT		MAX. LOAD @ INFLATION	
					IN	MM	IN	MM	IN	MM	IN	MM		IN	MM	MI	KM	LB	KG	LBS, PSI (KG, KPa)	LBS, PSI (KG, KPa)
					SINGLE		DUAL														
11R22.5	G	05310280000 # 05650960000 #	13	75	19.2	488	41.2	1046	11.7	297	13.1	331	8.25, 7.50	12.5	318	502	312	109	49	6175, 105 (2800, 720)	5840, 105 (2650, 720)
255/70R22.5	H	05310340000 # 05651230000 #	18	75	17.1	434	36.6	929	9.9	251	10.8	274	7.50, 8.25	11.3	287	566	352	93	42	5510, 120 (2500, 830)	5070, 120 (2300, 830)
295/75R22.5	G	05310270000 # 05650910000 #	13	75	18.5	470	39.7	1008	11.5	292	12.9	328	8.25, 9.00	12.5	318	522	324	104	47	6175, 110 (2800, 760)	5675, 110 (2575, 760)
285/75R24.5	G	05310250000	13	75	19.1	485	41.1	1044	11.5	292	12.9	329	8.25	12.5	318	504	313	110	50	6175, 110 (2800, 760)	5675, 110 (2575, 760)

TUBELESS TIRES ON 15 DEGREE DROP CENTER RIMS

Note - Rim listed first is the measuring rim. # = Intelligent Tire Article #. Minimum Dual Spacing calculated without chains. # - Exceeding the lawful speed limit is neither recommended nor endorsed. Overall widths will change 0.1 inch (2.5 mm) for each 1/4 inch change in rim width. Minimum dual spacing should be adjusted accordingly. Continental Tire The Americas, LLC reserves the right to change product specifications at any time without notice or obligations. Please consult rim manufacturers load and inflation limits. Never exceed rim manufacturers limits without permission of component manufacturer.

Features & Benefits

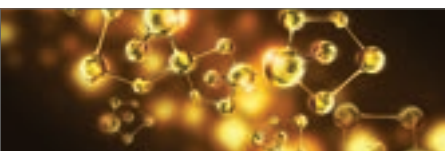

Advanced tread compound and optimized tread design provide exceptional mileage.

Ultra low rolling resistant trailer tire delivers outstanding fuel efficiency in long haul applications.



Built on the **Conti 3G Casing** for maximum retreadability.



Improved sidewall construction for defense against curbing, cuts and abrasions.

Applications: Trailers and free rolling positions.

 3G Casing	 SmartWay® Verified	 Intelligent Tire	 Retread Available
--	--	--	---

PRODUCT FEATURES ABOVE ONLY APPLY TO PRODUCTS IF THE MATCHING ICON IS DARKENED.

Conti HTL 3

Long Haul Mileage Trailer

GOODS PEOPLE CONSTRUCTION



PRODUCT DATA

TIRE SIZE	LOAD RANGE	ARTICLE NUMBER	TREAD DEPTH (32nds)	MAX SPEED (MPH)	STATIC LOADED RADIUS		OVERALL INFLATED DIAMETER		OVERALL INFLATED WIDTH		LOADED SECTION WIDTH		APPROVED RIM(S)	MINIMUM DUAL SPACING		REVS PER UNIT		TIRE WEIGHT		MAX. LOAD @ INFLATION	
					IN	MM	IN	MM	IN	MM	IN	MM		IN	MM	MI	KM	LB	KG	SINGLE	DUAL
					LBS, PSI (KG, KPa)		LBS, PSI (KG, KPa)														
11R22.5	G	05310820000 # 05653750000 #	13	75	19.2	488	41.2	1046	11.7	297	13.1	333	8.25, 7.50	12.5	318	502	312	109	49	6175, 105 (2800, 720)	5840, 105 (2650, 720)
295/75R22.5	G	05310830000 # 05653760000 #	13	75	18.5	470	39.7	1008	11.5	292	12.9	328	8.25, 9.00	12.5	318	521	324	104	47	6175, 110 (2800, 760)	5675, 110 (2575, 760)
11R24.5	G	05310840000 # 05653770000 #	13	75	20.1	511	43.2	1097	11.7	297	13.1	333	8.25, 7.50	12.5	318	479	298	117	53	6610, 105 (3000, 720)	6005, 105 (2725, 720)

TUBELESS TIRES ON 15 DEGREE DROP CENTER RIMS

Note - Rim listed first is the measuring rim. # = Intelligent Tire Article #. Minimum Dual Spacing calculated without chains. # - Exceeding the lawful speed limit is neither recommended nor endorsed. Overall widths will change 0.1 inch (2.5 mm) for each 1/4 inch change in rim width. Minimum dual spacing should be adjusted accordingly. Continental Tire The Americas, LLC reserves the right to change product specifications at any time without notice or obligations. Please consult rim manufacturers load and inflation limits. Never exceed rim manufacturers limits without permission of component manufacturer.

Features & Benefits

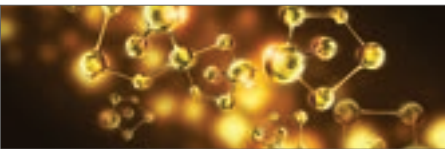

Advanced tread compound and optimized tread design provide exceptional mileage.

Ultra low rolling resistant trailer tire delivers outstanding fuel efficiency in long haul applications.



Built on the **Conti 3G Casing** for maximum retreadability.



Improved sidewall construction for defense against curbing, cuts and abrasions.

Applications: Trailers and free rolling positions.

			
3G Casing	SmartWay® Verified	Intelligent Tire	Retread Available

PRODUCT FEATURES ABOVE ONLY APPLY TO PRODUCTS IF THE MATCHING ICON IS DARKENED.

HTL1

Fuel-Efficient, Super Single Trailer

GOODS PEOPLE CONSTRUCTION



PRODUCT DATA

TIRE SIZE	LOAD RANGE	ARTICLE NUMBER	TREAD DEPTH (32nds)	MAX SPEED (MPH)	STATIC LOADED RADIUS		OVERALL INFLATED DIAMETER		OVERALL INFLATED WIDTH		LOADED SECTION WIDTH		APPROVED RIM(S)	MINIMUM DUAL SPACING		REVS PER UNIT		TIRE WEIGHT		MAX. LOAD @ INFLATION	
					IN	MM	IN	MM	IN	MM	IN	MM		IN	MM	MI	KM	LB	KG	LBS, PSI (KG, KPa)	LBS, PSI (KG, KPa)
445/50R22.5	L	0531000000 0565250000	13	75	18.1	460	39.2	996	17.3	439	19.0	483	14.00	N/A	N/A	528	328	179	81	10200,120 (4625, 830)	N/A

TUBELESS TIRES ON 15 DEGREE DROP CENTER RIMS

Ⓢ = Intelligent Tire Article #. # - Exceeding the lawful speed limit is neither recommended nor endorsed. Overall widths will change 0.1 inch (2.5 mm) for each 1/4 inch change in rim width. Minimum dual spacing should be adjusted accordingly. Continental Tire the Americas, LLC reserves the right to change product specifications at any time without notice or obligations. Please consult rim manufacturers load and inflation limits. Never exceed rim manufacturers limits without permission of component manufacturer.

Features & Benefits

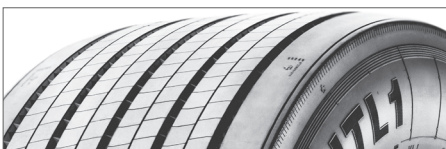

13/32" tread depth minimizes irregular wear.

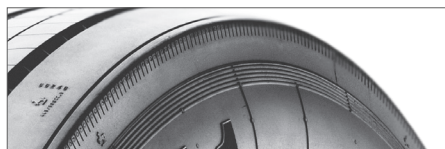

Shoulder defense groove provides protection against rapid shoulder wear.



Patented innovative groove technology leads to minimum stone retention, extending casing life.

Applications: Super single fitment for long haul, trailer position in highway service.

 3G Casing	 SmartWay® Verified	 Intelligent Tire	 Retread Available
--	--	--	---

PRODUCT FEATURES ABOVE ONLY APPLY TO PRODUCTS IF THE MATCHING ICON IS DARKENED.

HTL2 Eco Plus

17.5" Heavy Haul Trailer Tire

 GOODS  PEOPLE  CONSTRUCTION



PRODUCT DATA

TIRE SIZE	LOAD RANGE	ARTICLE NUMBER	TREAD DEPTH (32nds)	MAX SPEED (MPH)	STATIC LOADED RADIUS		OVERALL INFLATED DIAMETER		OVERALL INFLATED WIDTH		LOADED SECTION WIDTH		APPROVED RIM(S)	MINIMUM DUAL SPACING		REVS PER UNIT		TIRE WEIGHT		MAX. LOAD @ INFLATION	
					IN	MM	IN	MM	IN	MM	IN	MM		IN	MM	MI	KM	LB	KG	LBS, PSI (KG, KPa)	LBS, PSI (KG, KPa)
215/75R17.5	H	05311070000	15	75	14.1	359	30.4	772	8.5	215	9.1	231	6.00, 6.75	9.5	242	681	423	61	28	4805, 125 (2180, 860)	4540, 125 (2060, 860)
235/75R17.5	J	05311080000 * 04650170000 *	13	75	14.5	369	31.6	802	9.2	234	10.0	254	6.75, 7.50	10.6	269	656	407	65	29	6005, 125 (2725, 860)	5675, 125 (2575, 860)
245/70R17.5	J	05311090000 * 04650160000 *	13	75	14.5	369	31.6	802	9.2	234	10.0	254	6.75, 7.50	10.6	269	656	407	65	29	6005, 125 (2725, 860)	5675, 125 (2575, 860)

TUBELESS TIRES ON 15 DEGREE DROP CENTER RIMS

Note - Rim listed first is the measuring rim. * = Intelligent Tire Article #. Minimum Dual Spacing calculated without chains. # - Exceeding the lawful speed limit is neither recommended nor endorsed. Overall widths will change 0.1 inch (2.5 mm) for each 1/4 inch change in rim width. Minimum dual spacing should be adjusted accordingly. Continental Tire the Americas, LLC reserves the right to change product specifications at any time without notice or obligations. Please consult rim manufacturers load and inflation limits. Never exceed rim manufacturers limits without permission of component manufacturer.

Features & Benefits

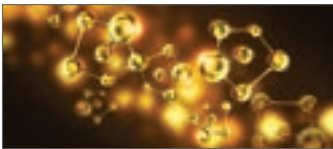

Low rolling resistance compound provides excellent fuel economy at cool operating temperatures.

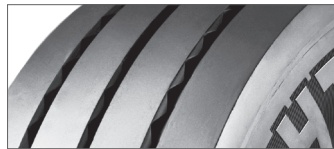

Advanced tread design provides long original mileage and low cost per mile.



Heavy ply construction for structural durability in large capacity applications.

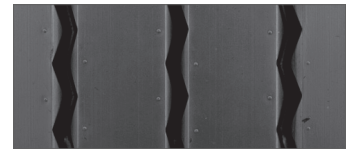

Patented groove technology leads to minimum stone retention, extending casing life.

Innovative groove geometry promotes efficient water evacuation, traction and wet braking capabilities throughout tire life.

Applications: Heavy haul and long haul trailer positions.



CONTINENTAL IS YOUR LEADER IN FUEL EFFICIENCY

Continental Tires Outperformed Other Top Brands in Fuel Efficiency Tests

Pumping Out Savings Tractors travel an average of **105,000 miles** every year. With a national average of 5.91 mpg, every tractor burns **over 17,700 gallons of fuel a year**. At \$3.89/gallon, **that's over \$69,000 in annual fuel costs!** With **Continental's demonstrated 7.35 mpg fuel efficiency** in Long Haul testing, fleets could achieve **an annual costs savings of over \$13,500 per truck!***

*Savings calculations based on "NACFE 2018 Annual Fleet Fuel Study" by the North American Council for Fuel Efficiency

Long Haul Tires Selected for Test



Conti EcoPlus HS3
Long Haul
11R22.5 | G | 19/32"



HDL2
Long Haul
11R22.5 | G | 26/32"



Conti EcoPlus HT3
Long Haul
11R22.5 | G | 13/32"

About Long Haul Tires

Tires for Long Haul use are designed for straight line, on-highway driving, distributing freight from state to state across great distances. Tires are optimized for high removal miles and fuel efficiency. To put our level of fuel efficiency to the test, Continental tires were used in a study by the PIT Group of FPIInnovations.

Long Haul Application Test Results

Tires	Double Coin	Continental	Michelin
Steer Tire	RR680	Conti EcoPlus HS3	X-Line Energy Z
Drive Tire	FD405	HDL2	X-Line Energy D
Trailer Tire	IM 105	Conti EcoPlus HT3	X-Line Energy T
Fuel consumption (L/100 km)	32.54	31.99	32.68
Fuel economy (mpg)	7.23	7.35	7.20
Rank	2	1	3

In Long Haul applications, **Continental is proven to provide a 2.11% savings** compared to Michelin X-Line Energy.

The Test

The fuel efficiency test procedure was based on TMC Fuel Consumption Test Procedure - Type III, RP 1103A. Each tire brand was tested on three identical 2016 International Prostar tractors powered by Cummins ISX15 engines, pulling 2018 Vanguard 53-foot two-axle cube van semi-trailers, at a cruising speed of 64.6 mph (104 km/h).

CONTINENTAL DELIVERS UP TO
2% FUEL SAVINGS
OVER OTHER TOP BRANDS

Contact your Continental representative to learn more!

Need a representative? Call 1 (800) 450-3187





Long Haul

Retread Product Overview

For Long Distance Highway Driving

Legend:



HDL 3 LTL-R
 



HDL2 DL
 

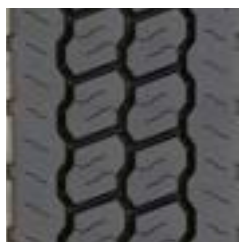

HDL
 

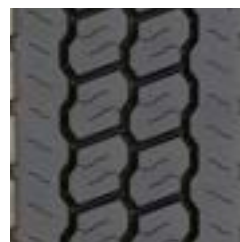

HDL Eco Plus
 

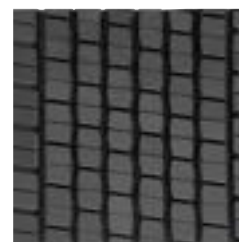

HDL2 Eco Plus
 



EcoPlus HT3
 



HTL
 

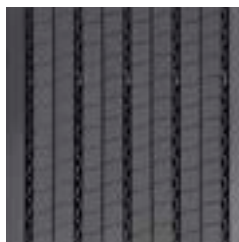



HTL1
 



ContiTread™ HDL 3 LTL-R | Long Haul, Single Axle Drive





PRODUCT DATA		 
WIDTH (MM)	ARTICLE NUMBER	TREAD DEPTH (32nds)
210	18215140000	22
220	18215150000	22
230	18215160000	22
240	18215170000	22

- Maximum fuel efficiency and high removal miles from advanced tread compounding.
- Resists irregular wear caused from high-torque single drive position, including heel-toe wear, thanks to rigid tread blocks that effectively control movement.
- 3-D matrix sipes provide superior traction and even wear.
- Maximum stone ejection due to superior groove geometry.

ContiTread™ HDL2 DL | Long Haul Drive, Deep Lug





PRODUCT DATA		 
WIDTH (MM)	ARTICLE NUMBER	TREAD DEPTH (32nds)
215	18217680000	28
225	18217690000	28
235	18217700000	28
245	18217710000	28

- Optimized compound with ultra deep tread delivers high mileage.
- Minimized wear and excellent traction over the life of the tire through a wide, closed shoulder tread and numerous tread blocks with multiple grip edges.
- Patented innovative groove technology leads to minimum stone retention, extending casing life.

ContiTread™ HDL | Long Haul Drive



PRODUCT DATA		 
WIDTH (MM)	ARTICLE NUMBER	TREAD DEPTH (32nds)
215	18217730000	26
225	18217740000	26
235	18217750000	26
245	18217760000	26
215	18217770000	20
225	18217780000	20
235	18217790000	20
215	18217820000	13
225	18217830000	13
235	18217840000	13

- Cut and tear resistant tread compound for excellent wear.
- Closed shoulder tread design provides even tread wear while still providing excellent traction.
- Patented innovative groove technology leads to minimum stone retention, extending casing life.



Legend:



SmartWay® Verified New Tire Available

ContiTread™ HDL Eco Plus | Fuel-Efficient, Long Haul Drive





PRODUCT DATA		 
WIDTH (MM)	ARTICLE NUMBER	TREAD DEPTH (32nds)
215	18204820000	26
225	18204830000	26
235	18204840000	26
245	18204850000	26
215	18204860000	20
225	18204870000	20
235	18204880000	20
245	18204890000	20

- Advanced, fuel-efficient compound provides long original mileage and rolling resistance.
- Closed shoulder tread design provides even tread wear while still providing excellent traction.
- Patented innovative groove technology leads to minimum stone retention, extending casing life.

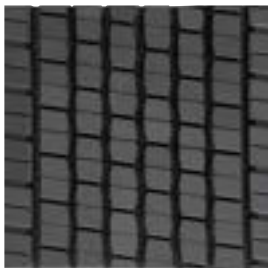
ContiTread™ HDL2 Eco Plus | Fuel-Efficient, Super Single Drive





PRODUCT DATA		 
WIDTH (MM)	ARTICLE NUMBER	TREAD DEPTH (32nds)
390	18209240000	24
400	18206780000	24

- Super single drive tire with advanced compounding for low rolling resistance and high mileage.

ContiTread™ EcoPlus HT3 | Fuel-Efficient, Long Haul Trailer



PRODUCT DATA		 
WIDTH (MM)	ARTICLE NUMBER	TREAD DEPTH (32nds)
215	18208620000	13
225	18208630000	13
235	18208640000	13
245*	18208650000	13



- Ultra low rolling resistant compounding.
- Optimized tread pattern resists irregular wear.
- 13/32nd tread depth for high removal mileage.
- Fuel Saving Edge technology available in 245mm tread width for maximum fuel efficiency.*

Legend:





ContiTread™ HTL | Long Haul Trailer

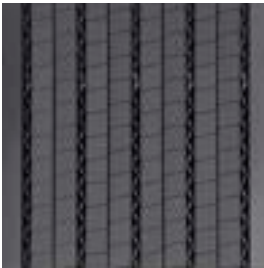

PRODUCT DATA			 	<ul style="list-style-type: none"> • 13/32" tread depth minimizes tread squirm and irregular wear. • Patented innovative groove technology leads to minimum stone retention, extending casing life.
WIDTH (MM)	ARTICLE NUMBER	TREAD DEPTH (32nds)		
200	18208720000	13		
210	18205420000	13		
220	18205440000	13		
230	18205460000	13		
240	18206800000	13		

ContiTread™ HTL1 | Fuel-Efficient, Super Single Trailer



PRODUCT DATA			 	<ul style="list-style-type: none"> • Optimized compound for regional and long hauling delivers high mileage. • Proven 13/32" tread design. • New solid shoulder design for durability. • Patented innovative groove technology leads to minimum stone retention, extending casing life.
WIDTH (MM)	ARTICLE NUMBER	TREAD DEPTH (32nds)		
390	18214670000	13		
400	18214680000	13		

EPA SmartWay®

Reducing Transportation-Related Emissions and Improving Supply Chain Fuel Efficiency

Verified Low-Rolling Resistance Tire Products

The EPA has determined that certain tire product models and technologies can reduce NOx emissions and fuel use by 3 percent or more, relative to the best-selling products for line haul class 8 tractor trailers. These improvements are achieved under the following conditions:

- Tires are used in the correct axle positions.
- Verified low rolling resistance tires are installed on all of the axle positions of the tractor and trailer.
- All tires must be properly inflated according to the manufacturer's specifications.

For more information on SmartWay® or to review the list of SmartWay verified low rolling resistance tires and retread technologies, visit www.epa.gov/smartway.

More tires and retreads may currently be verified by SmartWay®, always review the SmartWay website for current information.



Fuel Savings



Cleaner Air



Cost Savings



Environmentally Friendly

The following Continental low-rolling resistance tire products are SmartWay® verified when used on class 8, line-haul tractor trailers:



ContiTread™ Retreads: HDL 3 LTL-R, HDL Eco Plus, HDR1 Eco Plus, HDL2 Eco Plus, HTL1, EcoPlus HT3



TrukFix Program with 360°Smart App For Emergency Roadside Assistance

About the TrukFix Program

TrukFix is Continental's emergency roadside assistance program. It is available in the U.S. and Canada to qualified National Account customers, Premier Fleet members, and OOIDA members.

Fulfilling Your Fleet Requirements

TrukFix can accommodate your fleet's emergency roadside assistance requirements. Share your preferences in advance via our online form, and TrukFix dispatchers will ensure that your needs are met. Tell us your tire/retread preferences, photo documentation requirements and more at www.TrukFix.com.



About the TrukFix Web App

360°Smart for TrukFix is a simple web app that enables the user to submit, process, and track TrukFix emergency roadside assistance requests in real-time.

It ties directly into systems used by TrukFix dispatchers, making information visible to:

- Continental TrukFix Dispatchers
- Fleet Dispatchers
- Drivers
- Fleet Managers
- Service Providers (Dealers)

Compatible with iOS and Android phones and tablets, along with desktop devices. Visit www.TrukFix.com to learn more about its features and benefits.

CALL 877-TRUKFIX - 24/7 EMERGENCY HOTLINE



Better Customer Service

- 24/7 access to professional North American dispatchers
- Verified network of commercial dealers who stock Continental and General Tire products for roadside assistance
- Request full service or simply locate the nearest dealer



Better Communication

- Real-time tracking of the incident until trucks are back on the road
- Follow-up by our dispatchers ensures your repairs are completed
- Service case history reporting, complete with failure photos



Better Pricing

- No enrollment or membership fee - pay for services as they are used
- Regulated, predictable pricing as a published tire and service program
- Simple, convenient billing through our National Account invoicing system



Long Removal Mileage // Cut/Chip Resistance // Resistance to High Scrub // Robust Casing Construction

Regional

For Highway & Local Driving

Engineered for your application. Tires for Regional use are designed for applications where vehicles spend the majority of their time on pavement with multiple stops through inter-city operations, and mostly paved roads. Tires are optimized for high scrub, cut-chip resistance applications, as well as traction.

IMPORTANT NOTE: Tire Products are now classified by route. Product details are subject to change, please visit our website or contact your local sales representative for the most up to date information.

Legend:

			
3G Casing	SmartWay® Verified	Intelligent Tire	Retread Available

PRODUCT FEATURES ABOVE ONLY APPLY TO PRODUCTS IF THE MATCHING ICON IS DARKENED.

Regional

Truck Tire Product Overview



Conti HSR 3
   



HSR2
   



HSR2 SA
   



HTR2
   



HDR+
   



HDW2
   



Conti Scandinavia HD3
   



HDR
   



Conti Hybrid HT3
   

			
3G Casing	SmartWay® Verified	Intelligent Tire	Retread Available

PRODUCT FEATURES ABOVE ONLY APPLY TO PRODUCTS IF THE MATCHING ICON IS DARKENED.

Regional (19.5" or Smaller Products)

Truck Tire Product Overview

16" Tires



Conti LAR 3 (16")
3G   

17.5" Tires



LSR1 (17.5")
3G   



HTR2 (17.5")
3G   

19.5" Tires



Conti HSR 5 (19.5")
3G   



Conti Hybrid HS3 (19.5")
3G   



Conti HDR 5 (19.5")
3G   



Conti Hybrid HD3 (19.5")
3G   



Scandinavia HD3 (19.5")
3G   



Conti Hybrid HT3 (19.5")
3G   

			
3G Casing	SmartWay® Verified	Intelligent Tire	Retread Available

PRODUCT FEATURES ABOVE ONLY APPLY TO PRODUCTS IF THE MATCHING ICON IS DARKENED.

Conti HSR 3

Regional All-Position

 GOODS  PEOPLE  CONSTRUCTION



PRODUCT DATA

TIRE SIZE	LOAD RANGE	ARTICLE NUMBER	TREAD DEPTH (32nds)	MAX SPEED (MPH)	STATIC LOADED RADIUS		OVERALL INFLATED DIAMETER		OVERALL INFLATED WIDTH		LOADED SECTION WIDTH		APPROVED RIMS	MINIMUM DUAL SPACING		REVS PER UNIT		TIRE WEIGHT		MAX. LOAD @ INFLATION	
					IN	MM	IN	MM	IN	MM	IN	MM		IN	MM	MI	KM	LB	KG	LBS, PSI (KG, KPa)	LBS, PSI (KG, KPa)
11R22.5	G	05124370000 #05652560000	23	75	19.5	495	41.9	1064	11.6	295	13.0	330	8.25, 7.50	12.5	318	494	307	131	59	6175, 105 (2800, 720)	5840, 105 (2650, 720)
11R22.5	H	05124380000 #05652570000	23	75	19.5	495	41.9	1064	11.6	295	13.0	330	8.25, 7.50	12.5	318	494	307	133	60	6610, 120 (3000, 830)	6005, 120 (2725, 830)
12R22.5	H	05124390000 #05652580000	23	75	20.2	513	42.8	1086	11.9	302	13.1	333	9.00, 8.25	13.7	348	484	301	147	67	7390, 120 (3350, 830)	6780, 120 (3075, 830)
295/75R22.5	H	05124410000 #05652600000	23	75	18.9	480	40.2	1022	11.8	299	12.9	328	8.25, 9.00	13.4	340	514	320	127	58	7160, 120 (3250, 830)	6610, 120 (3000, 830)
11R24.5	H	05124430000 #05652620000	23	75	20.5	521	43.8	1113	11.6	295	13.0	330	8.25, 7.50	12.5	318	473	294	143	65	7160, 120 (3250, 830)	6610, 120 (3000, 830)
285/75R24.5	H	05124450000 #05652640000	23	75	19.5	496	41.6	1057	11.8	300	12.9	328	8.25	12.5	318	498	309	133	60	6780, 120 (3075, 830)	6175, 120 (2800, 830)

TUBELESS TIRES ON 15 DEGREE DROP CENTER RIMS

PLEASE NOTE: THIS PRODUCT WAS PREVIOUSLY NAMED CONTI CROSSTRAC HA3.

Note - Rim listed first is the measuring rim. # = Intelligent Tire Article #. Minimum Dual Spacing calculated without chains. # - Exceeding the lawful speed limit is neither recommended nor endorsed. Overall widths will change 0.1 inch (2.5 mm) for each 1/4 inch change in rim width. Minimum dual spacing should be adjusted accordingly. Continental Tire the Americas, LLC reserves the right to change product specifications at any time without notice or obligations. Please consult rim manufacturers load and inflation limits. Never exceed rim manufacturers limits without permission of component manufacturer.

Features & Benefits

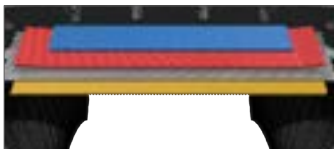

Rigid belt package with full width top belt and extra sidewall protection for increased durability.



Zigzag center groove geometry increases the number of biting edges for increased traction.



Pyramidal stone ejection system for maximum casing protection.



Built on the innovative **Conti 3G Casing** for maximum retreadability.



Mileage Improvement vs. HSR2

*Based on projected calculations.

Applications: Regional hauling and on/off road, all-position.

			
3G Casing	SmartWay® Verified	Intelligent Tire	Retread Available

PRODUCT FEATURES ABOVE ONLY APPLY TO PRODUCTS IF THE MATCHING ICON IS DARKENED.

HSR2

Regional All-Position

 GOODS  PEOPLE  CONSTRUCTION



PRODUCT DATA



TIRE SIZE	LOAD RANGE	ARTICLE NUMBER	TREAD DEPTH (32nds)	MAX SPEED (MPH)	STATIC LOADED RADIUS		OVERALL INFLATED DIAMETER		OVERALL INFLATED WIDTH		LOADED SECTION WIDTH		APPROVED RIM(S)	MINIMUM DUAL SPACING		REVS PER UNIT		TIRE WEIGHT		MAX. LOAD @ INFLATION	
					IN	MM	IN	MM	IN	MM	IN	MM		IN	MM	IN	MM	MI	KM	LB	KG
10R22.5	G	05686570000	20	75	18.8	478	40.0	1016	10.0	254	10.8	274	7.50, 6.75, 8.25	11.4	290	518	322	100	45	5675, 115 (2575, 790)	5355, 115 (2430, 790)
11R22.5	G	05686300000 #05651060000	23	75	19.4	493	41.6	1057	11.1	282	12.0	305	8.25	12.5	318	498	309	119	54	6175, 105 (2800, 720)	5840, 105 (2650, 720)
11R22.5	H	05686310000 #05650880000	23	75	19.4	493	41.6	1057	11.1	282	12.0	305	8.25	12.5	318	498	309	121	55	6610, 120 (3000, 830)	6005, 120 (2725, 830)
12R22.5	H	05120880000 #05651750000	23	75	20.1	510	42.8	1088	11.7	297	12.9	327	9.00, 8.25	13.5	343	483	300	135	61	7390, 120 (3350, 830)	6780, 120 (3075, 830)
275/80R22.5	H	05686350000 #05651080000	23	75	18.7	475	40.0	1016	11.1	282	12.6	320	8.25	12.5	318	518	322	115	52	7160, 120 (3250, 830)	6610, 120 (3000, 830)
11R24.5	H	05686330000 #05651110000	23	75	20.4	518	43.5	1105	11.1	282	12.0	305	8.25	12.5	318	476	296	130	59	7160, 120 (3250, 830)	6610, 120 (3000, 830)
285/75R24.5	H	05687020000 #05652200000	23	75	19.4	493	41.3	1049	10.7	272	12.1	307	8.25	12.5	318	501	311	120	55	6780, 120 (3075, 830)	6175, 120 (2800, 830)

TUBELESS TIRES ON 15 DEGREE DROP CENTER RIMS

Note - Rim listed first is the measuring rim. # = Intelligent Tire Article #. Minimum Dual Spacing calculated without chains. # - Exceeding the lawful speed limit is neither recommended nor endorsed. Overall widths will change 0.1 inch (2.5 mm) for each 1/4 inch change in rim width. Minimum dual spacing should be adjusted accordingly. Continental Tire the Americas, LLC reserves the right to change product specifications at any time without notice or obligations. Please consult rim manufacturers load and inflation limits. Never exceed rim manufacturers limits without permission of component manufacturer.

Features & Benefits



23/32" deep improved cut and chip resistant tread compound for optimal performance.



Protective curb rib for high scrub applications.

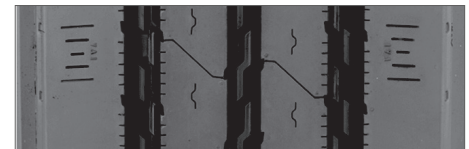

Patented innovative groove technology leads to minimum stone retention, extending casing life.

Patented groove geometry for better resistance to cracking and tearing.

Applications: Regional hauling and on/off road, all-position.

3G Casing	SmartWay® Verified	Intelligent Tire	Retread Available

PRODUCT FEATURES ABOVE ONLY APPLY TO PRODUCTS IF THE MATCHING ICON IS DARKENED.

HSR2 SA

Regional All-Position

GOODS PEOPLE CONSTRUCTION



REGIONAL

PRODUCT DATA

TIRE SIZE	LOAD RANGE	ARTICLE NUMBER	TREAD DEPTH (32nds)	MAX SPEED (MPH)	STATIC LOADED RADIUS		OVERALL INFLATED DIAMETER		OVERALL INFLATED WIDTH		LOADED SECTION WIDTH		APPROVED RIM(S)	MINIMUM DUAL SPACING		REVS PER UNIT		TIRE WEIGHT		MAX. LOAD @ INFLATION			
					IN	MM	IN	MM	IN	MM	IN	MM		IN	MM	IN	MM	MI	KM	LB	KG	SINGLE	DUAL
					LBS, PSI (KG, KPa)		LBS, PSI (KG, KPa)																
255/70R22.5	H	05122460000 #05652210000#	18	75	17.1	434	36.6	930	10.0	255	10.8	274	8.25, 7.50	11.3	287	565	351	88	40	5510, 120 (2500, 830)	5070, 120 (2300, 830)		
275/70R22.5	J	05121290000 #05651640000#	18	75	17.8	451	37.9	962	10.7	272	11.6	295	8.25	12.4	315	547	340	107	49	6940, 130 (3150, 900)	6395, 130 (2900, 900)		
315/80R22.5	L	05120980000 #05651720000#	19	75	19.8	503	42.5	1080	12.5	317	12.5	316	9.00, 8.25*	13.8	351	487	303	143	65	9090, 130 (4125, 900)	8270, 130 (3750, 900)		

TUBELESS TIRES ON 15 DEGREE DROP CENTER RIMS

*315/80R22.5 tires used on 8.25" rims are restricted to a maximum of 7610 lbs at 120 psi.

Note - Rim listed first is the measuring rim. # = Intelligent Tire Article #. Minimum Dual Spacing calculated without chains. # - Exceeding the lawful speed limit is neither recommended nor endorsed. Overall widths will change 0.1 inch (2.5 mm) for each 1/4 inch change in rim width. Minimum dual spacing should be adjusted accordingly. 315/80R22.5 tires used on 8.25" rims are restricted to a maximum of 7610 lbs at 120 psi. Continental Tire the Americas, LLC reserves the right to change product specifications at any time without notice or obligations. Please consult rim manufacturers load and inflation limits. Never exceed rim manufacturers limits without permission of component manufacturer.

Features & Benefits



Maximum tire life expectancy and wet traction capabilities through **customized tread geometry**.

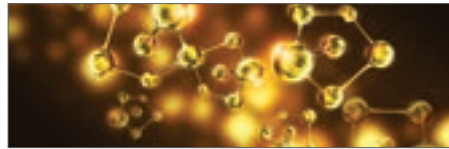

Superb wet traction capabilities with minimum wear through innovative tread compound.



Ideal for buses and larger recreational vehicles.

Applications: Steer or all-position regional/long haul, for bus or large RV traffic.

			
3G Casing	SmartWay® Verified	Intelligent Tire	Retread Available

PRODUCT FEATURES ABOVE ONLY APPLY TO PRODUCTS IF THE MATCHING ICON IS DARKENED.

HTR2

Regional All-Position

 GOODS  PEOPLE  CONSTRUCTION



PRODUCT DATA

TIRE SIZE	LOAD RANGE	ARTICLE NUMBER	TREAD DEPTH (32nds)	MAX SPEED (MPH)	STATIC LOADED RADIUS		OVERALL INFLATED DIAMETER		OVERALL INFLATED WIDTH		LOADED SECTION WIDTH		APPROVED RIM(S)	MINIMUM DUAL SPACING		REVS PER UNIT		TIRE WEIGHT		MAX. LOAD @ INFLATION	
					IN	MM	IN	MM	IN	MM	IN	MM		IN	MM	MI	KM	LB	KG	LBS, PSI (KG, KPa)	LBS, PSI (KG, KPa)
385/65R22.5	L	05320080000 # 05651250000	21	68	19.5	495	42.0	1067	14.8	376	16.3	414	11.75, 12.25	N/A	N/A	493	306	165	75	9920, 130 (4500, 900)	N/A
425/65R22.5	L	05320260000 # 05651620000	22	68	20.3	515	44.3	1126	16.6	422	18.0	457	13.00, 14.00, 12.15	N/A	N/A	467	290	185	84	11,400, 120 (5150, 830)	N/A

TUBELESS TIRES ON 15 DEGREE DROP CENTER RIMS

Note - Rim listed first is the measuring rim. ## = Intelligent Tire Article #. Minimum Dual Spacing calculated without chains. These specifications subject to change without notice. # - Exceeding the lawful speed limit is neither recommended nor endorsed. Overall widths will change 0.1 inch (2.5 mm) for each 1/4 inch change in rim width. Minimum dual spacing should be adjusted accordingly. Continental Tire the Americas, LLC reserves the right to change product specifications at any time without notice or obligations. Please consult rim manufacturers load and inflation limits. Never exceed rim manufacturers limits without permission of component manufacturer.

Features & Benefits

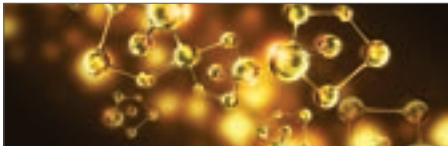

High mileage achieved through precise balance of compound and tread geometry.

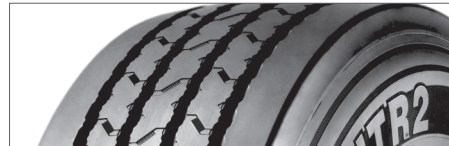

Tread pattern designed for increased stability and reduced noise.

Increased fuel efficiency due to optimized tread pattern and reduced tire weight.

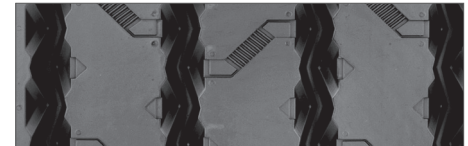

Patented innovative groove technology leads to minimum stone retention, extending casing life.

Also available in **17.5" Trailer Tire** on pg. 57.

Applications: Local and long haul, all-position service.

			
3G Casing	SmartWay® Verified	Intelligent Tire	Retread Available

PRODUCT FEATURES ABOVE ONLY APPLY TO PRODUCTS IF THE MATCHING ICON IS DARKENED.

HDR2+

Regional Drive

 GOODS  PEOPLE  CONSTRUCTION



REGIONAL

PRODUCT DATA



TIRE SIZE	LOAD RANGE	ARTICLE NUMBER	TREAD DEPTH (32nds)	MAX SPEED (MPH)	STATIC LOADED RADIUS		OVERALL INFLATED DIAMETER		OVERALL INFLATED WIDTH		LOADED SECTION WIDTH		APPROVED RIM(S)	MINIMUM DUAL SPACING		REVS PER UNIT		TIRE WEIGHT		MAX. LOAD @ INFLATION	
					IN	MM	IN	MM	IN	MM	IN	MM		IN	MM	MI	KM	LB	KG	LBS, PSI (KG, KPa)	LBS, PSI (KG, KPa)
*10R22.5	G	05224330000 #05653430000#	24	75	19.0	483	40.4	1026	10.0	254	11.0	278	7.50, 6.75, 8.25	11.4	290	513	318	103	47	5675, 115 (2575, 790)	5355, 115 (2430, 790)
11R22.5	G	05224340000 #05653360000#	30	75	19.8	502	42.2	1071	11.6	295	13.0	330	8.25, 7.50	12.5	318	491	305	129	59	6175, 105 (2800, 720)	5840, 105 (2650, 720)
11R22.5	H	05224350000 #05653370000#	30	75	19.8	502	42.2	1071	11.6	295	13.0	330	8.25, 7.50	12.5	318	491	305	132	60	6610, 120 (3000, 830)	6005, 120 (2725, 830)
12R22.5	H	05224360000 #05653420000#	30	75	20.3	515	43.2	1098	11.9	301	13.2	335	9.00, 8.25	13.5	343	479	297	149	68	7390, 120 (3350, 830)	6780, 120 (3075, 830)
295/75R22.5	G	05224370000 #05653390000#	30	75	19.0	483	40.7	1034	11.5	292	12.9	328	8.25, 9.00	12.5	318	509	316	124	56	6175, 110 (2800, 760)	5675, 110 (2575, 760)
295/75R22.5	H	05224380000 #05653400000#	30	75	19.0	483	40.7	1034	11.5	292	12.9	328	8.25, 9.00	12.5	318	509	316	126	57	6610, 120 (3000, 830)	6005, 120 (2725, 830)
11R24.5	H	05224390000 #05653380000#	30	75	20.6	524	44.2	1123	11.6	295	13.0	330	8.25, 7.50	12.5	318	468	291	141	64	7160, 120 (3250, 830)	6610, 120 (3000, 830)

TUBELESS TIRES ON 15 DEGREE DROP CENTER RIMS

Note - Rim listed first is the measuring rim. # = Intelligent Tire Article #. Minimum Dual Spacing calculated without chains. # - Exceeding the lawful speed limit is neither recommended nor endorsed. Overall widths will change 0.1 inch (2.5 mm) for each 1/4 inch change in rim width. Minimum dual spacing should be adjusted accordingly. 315/80R22.5 tires used on 8.25" rims are restricted to a maximum of 7610 lbs at 120 psi. Continental Tire the Americas, LLC reserves the right to change product specifications at any time without notice or obligations. Please consult rim manufacturers load and inflation limits. Never exceed rim manufacturers limits without permission of component manufacturer. *10R22.5 is a 4 rib pattern for the HDR2+ tire.

Features & Benefits

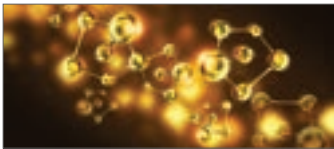

Improved cap/base tread compounds for improved wear performance, wet traction and cut/chip/chunk performance.



Optimized contour and **balanced footprint distribution** for extended tread life and product performance.

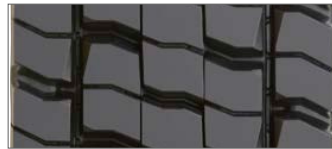

Chamfered tread block geometry to withstand higher drive axle torque with reduced drive tire wear conditions such as tearing and cracking.



Built on the **Conti 3G Casing** for maximum retreadability.

Applications: Regional haul drive positions. On/Off-highway service.

			
3G Casing	SmartWay® Verified	Intelligent Tire	Retread Available

PRODUCT FEATURES ABOVE ONLY APPLY TO PRODUCTS IF THE MATCHING ICON IS DARKENED.

HDW2

Regional Drive for Extreme Weather Conditions

 GOODS  PEOPLE  CONSTRUCTION



PRODUCT DATA

TIRE SIZE	LOAD RANGE	ARTICLE NUMBER	TREAD DEPTH (32nds)	MAX SPEED (MPH)	STATIC LOADED RADIUS		OVERALL INFLATED DIAMETER		OVERALL INFLATED WIDTH		LOADED SECTION WIDTH		APPROVED RIM(S)	MINIMUM DUAL SPACING		REVS PER UNIT		TIRE WEIGHT		MAX. LOAD @ INFLATION	
					IN	MM	IN	MM	IN	MM	IN	MM		IN	MM	MI	KM	LB	KG	LBS, PSI (KG, KPa)	LBS, PSI (KG, KPa)
					SINGLE		DUAL														
11R22.5	H	05230780000 # 05655110000	27	75	19.6	497	41.9	1063	11.6	294	13.0	329	8.25	12.5	318	495	307	131	59	6940, 120 (3150, 830)	6395, 120 (2900, 830)
11R24.5	H	05230800000 # 05655100000	27	75	20.6	522	43.9	1114	11.6	294	13.0	329	8.25	12.5	318	472	293	140	63	7160, 120 (3250, 830)	6610, 120 (3000, 830)
295/75R22.5	H	05230650000 # 05654080000	27	75	19.1	486	40.6	1031	11.7	297	12.6	320	8.25, 9.00	12.5	318	510	317	126	57	6610, 120 (3000, 830)	6005, 120 (2725, 830)

TUBELESS TIRES ON 15 DEGREE DROP CENTER RIMS

Note - Rim listed first is the measuring rim. # = Intelligent Tire Article #. Minimum Dual Spacing calculated without chains. # - Exceeding the lawful speed limit is neither recommended nor endorsed. Overall widths will change 0.1 inch (2.5 mm) for each 1/4 inch change in rim width. Minimum dual spacing should be adjusted accordingly. Continental Tire the Americas, LLC reserves the right to change product specifications at any time without notice or obligations. Please consult rim manufacturers load and inflation limits. Never exceed rim manufacturers limits without permission of component manufacturer. 315/80R22.5 tires used on 8.25" rims are restricted to a maximum of 7610 lbs.

Features & Benefits



All season tires ensures optimum performance in a variety of winter conditions from ice to deep snow.



Directional tread design with more than 1000 sipes provides excellent traction and lateral stability.

Siping engineered with Continental's **3D-Technology**.



More grip on snow and ice thanks to new **special winter compound**.



39% more tread volume compared to HDW by utilizing the all new Conti 3G Casing.



This product is 3PMSF Certified.



This product is Mud + Snow Certified.

Applications: Drive axle tire for extreme weather conditions.

3G Casing	SmartWay® Verified	Intelligent Tire	Retread Available

PRODUCT FEATURES ABOVE ONLY APPLY TO PRODUCTS IF THE MATCHING ICON IS DARKENED.

Conti Scandinavia HD3

Regional Drive for Extreme Weather Conditions

GOODS PEOPLE CONSTRUCTION



REGIONAL

PRODUCT DATA

TIRE SIZE	LOAD RANGE	ARTICLE NUMBER	TREAD DEPTH (32nds)	MAX SPEED (MPH)	STATIC LOADED RADIUS		OVERALL INFLATED DIAMETER		OVERALL INFLATED WIDTH		LOADED SECTION WIDTH		APPROVED RIMS)	MINIMUM DUAL SPACING		REVS PER UNIT		TIRE WEIGHT		MAX. LOAD @ INFLATION	
					IN	MM	IN	MM	IN	MM	IN	MM		IN	MM	MI	KM	LB	KG	LBS, PSI (KG, KPa)	LBS, PSI (KG, KPa)
11R22.5	H	05230560000	27	75	19.8	502	42.0	1067	11.6	295	12.7	323	8.25, 7.50	12.5	318	493	306	130	59	6610, 120 (3000, 830)	6005, 120 (2725, 830)
11R24.5	H	05230570000	27	75	20.6	524	44.0	1118	11.6	295	12.7	323	8.25, 7.50	12.5	318	470	292	140	64	7160, 120 (3250, 825)	6610, 120 (3000, 830)

TUBELESS TIRES ON 15 DEGREE DROP CENTER RIMS

Note - Rim listed first is the measuring rim. # = Intelligent Tire Article #. Minimum Dual Spacing calculated without chains. # - Exceeding the lawful speed limit is neither recommended nor endorsed. Overall widths will change 0.1 inch (2.5 mm) for each 1/4 inch change in rim width. Minimum dual spacing should be adjusted accordingly. Continental Tire the Americas, LLC reserves the right to change product specifications at any time without notice or obligations. Please consult rim manufacturers load and inflation limits. Never exceed rim manufacturers limits without permission of component manufacturer.

Features & Benefits

Multiple sipe technologies including 3D siping to provide traction during winter weather conditions throughout the life of the tire.



Directional M + S tread pattern delivers even wear and traction in both snow or mud.

All-Season compounding to deliver performance during any season.

Conti 3G casing with an **extended 4th belt for enhanced retreadability.**

This product is 3PMSF Certified.

This product is Mud + Snow Certified.

Also available in **19.5" Tire** on pg. 62.

Applications: Drive axle tire for extreme weather conditions.

			
3G Casing	SmartWay® Verified	Intelligent Tire	Retread Available

PRODUCT FEATURES ABOVE ONLY APPLY TO PRODUCTS IF THE MATCHING ICON IS DARKENED.





Conti Hybrid HD3

Super Regional Drive

GOODS PEOPLE CONSTRUCTION



REGIONAL

PRODUCT DATA																						
TIRE SIZE	LOAD RANGE	ARTICLE NUMBER	TREAD DEPTH (32nds)	MAX SPEED (MPH)	STATIC LOADED RADIUS		OVERALL INFLATED DIAMETER		OVERALL INFLATED WIDTH		LOADED SECTION WIDTH		APPROVED RIM(S)	MINIMUM DUAL SPACING		REVS PER UNIT		TIRE WEIGHT		MAX. LOAD @ INFLATION		
					IN	MM	IN	MM	IN	MM	IN	MM		IN	MM	MI	KM	LB	KG	LBS, PSI (KG, kPa)	LBS, PSI (KG, kPa)	
275/70R22.5	H	05210920000	22	81	17.6	447	38.3	974	10.9	276	11.3	287	8.25, 7.50	12.1	307	551	342	115	52	6940, 130 (3150, 900)	6395, 130 (2900, 900)	
TUBELESS TIRES ON 15 DEGREE DROP CENTER RIMS																						
<p>Note - Rim listed first is the measuring rim. # = Intelligent Tire Article #. Minimum Dual Spacing calculated without chains. # - Exceeding the lawful speed limit is neither recommended nor endorsed. Overall widths will change 0.1 inch (2.5 mm) for each 1/4 inch change in rim width. Minimum dual spacing should be adjusted accordingly. Continental Tire the Americas, LLC reserves the right to change product specifications at any time without notice or obligations. Please consult rim manufacturers load and inflation limits. Never exceed rim manufacturers limits without permission of component manufacturer.</p>																						

Features & Benefits

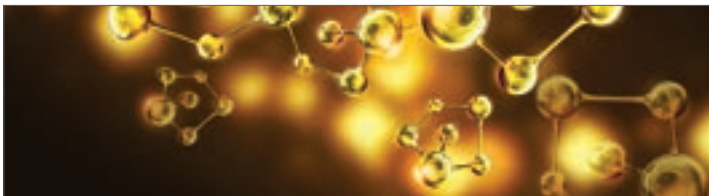

Fuel-efficient tread compound delivers exceptional rolling resistance balanced with mileage.

Also available in **19.5" Tire** on pg. 61.

Applications: Combined long haul highway and regional tandem drive position.

			
3G Casing	SmartWay® Verified	Intelligent Tire	Retread Available

PRODUCT FEATURES ABOVE ONLY APPLY TO PRODUCTS IF THE MATCHING ICON IS DARKENED.

HDR

Regional Drive

 GOODS  PEOPLE  CONSTRUCTION



PRODUCT DATA

TIRE SIZE	LOAD RANGE	ARTICLE NUMBER	TREAD DEPTH (32nds)	MAX SPEED (MPH)	STATIC LOADED RADIUS		OVERALL INFLATED DIAMETER		OVERALL INFLATED WIDTH		LOADED SECTION WIDTH		APPROVED RIM(S)	MINIMUM DUAL SPACING		REVS PER UNIT		TIRE WEIGHT		MAX. LOAD @ INFLATION	
					IN	MM	IN	MM	IN	MM	IN	MM		IN	MM	MI	KM	LB	KG	LBS, PSI (KG, KPa)	LBS, PSI (KG, KPa)
255/70R22.5	H	05223330000	26	81	17.3	439	37.0	940	10.0	255	10.8	274	8.25, 7.50	11.3	287	559	347	96	44	5510, 120 (2500, 830)	5070, 120 (2300, 830)

TUBELESS TIRES ON 15 DEGREE DROP CENTER RIMS

Note - Rim listed first is the measuring rim. Minimum Dual Spacing calculated without chains. # - Exceeding the lawful speed limit is neither recommended nor endorsed. Overall widths will change 0.1 inch (2.5 mm) for each 1/4 inch change in rim width. Minimum dual spacing should be adjusted accordingly. Continental Tire the Americas, LLC reserves the right to change product specifications at any time without notice or obligations. Please consult rim manufacturers load and inflation limits. Never exceed rim manufacturers limits without permission of component manufacturer.

Features & Benefits



Multi-service tread compound for local and long haul service.



Offset center tread blocks provide excellent all weather traction.

Tapered tread grooves reduce stone retention for long casing life and multiple retreads.

Applications: Drive position, short and long haul. On/off highway service.

 3G Casing	 SmartWay® Verified	 Intelligent Tire	 Retread Available
---	---	---	--

PRODUCT FEATURES ABOVE ONLY APPLY TO PRODUCTS IF THE MATCHING ICON IS DARKENED.

Conti Hybrid HT3

Durable Fuel-Efficient Trailer for Spread-Axes

 GOODS  PEOPLE  CONSTRUCTION



REGIONAL

PRODUCT DATA

TIRE SIZE	LOAD RANGE	ARTICLE NUMBER	TREAD DEPTH (32nds)	MAX SPEED (MPH)	STATIC LOADED RADIUS		OVERALL INFLATED DIAMETER		OVERALL INFLATED WIDTH		LOADED SECTION WIDTH		APPROVED RIM(S)	MINIMUM DUAL SPACING		REVS PER UNIT		TIRE WEIGHT		MAX. LOAD @ INFLATION	
					IN	MM	IN	MM	IN	MM	IN	MM		IN	MM	MI	KM	LB	KG	LBS, PSI (KG, KPa)	LBS, PSI (KG, KPa)
11R22.5	G	05321060000 *05651000000*	16	75	19.2	488	41.2	1046	11.1	282	12.0	305	8.25	12.5	318	502	312	111	50	6175, 105 (2800, 720)	5840, 105 (2650, 720)
11R22.5	H	05321250000 *05651040000*	16	75	19.2	488	41.2	1046	11.1	282	12.0	305	8.25	12.5	318	502	312	113	51	6610, 120 (3000, 830)	6005, 120 (2725, 830)
295/75R22.5	G	05321040000 *05651650000*	16	75	18.5	470	39.6	1006	11.1	282	12.6	320	8.25	12.5	318	523	325	107	49	6175, 110 (2800, 760)	5675, 110 (2575, 760)
11R24.5	G	05321070000 *05651050000*	16	75	20.2	513	43.1	1095	11.1	282	12.0	305	8.25	12.5	318	480	298	119	54	6610, 105 (3000, 720)	6005, 105 (2725, 720)
11R24.5	H	05321260000 *05651190000*	16	75	20.2	513	43.1	1095	11.1	282	12.0	305	8.25	12.5	318	480	298	122	55	7160, 120 (3250, 830)	6610, 120 (3000, 830)
285/75R24.5	H	05321280000 *05651210000*	16	75	19.2	488	40.9	1039	10.7	272	12.1	307	8.25	12.5	318	506	314	114	52	6780, 120 (3075, 830)	6175, 120 (2800, 830)

TUBELESS TIRES ON 15 DEGREE DROP CENTER RIMS

Note - Rim listed first is the measuring rim. * = Intelligent Tire Article #. Minimum Dual Spacing calculated without chains. # - Exceeding the lawful speed limit is neither recommended nor endorsed. Overall widths will change 0.1 inch (2.5 mm) for each 1/4 inch change in rim width. Minimum dual spacing should be adjusted accordingly. Continental Tire the Americas, LLC reserves the right to change product specifications at any time without notice or obligations. Please consult rim manufacturers load and inflation limits. Never exceed rim manufacturers limits without permission of component manufacturer.

Features & Benefits

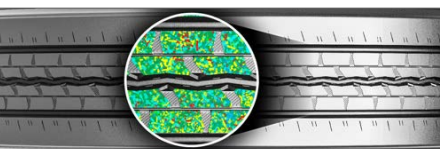

Advanced tread compound to achieve performance in high scrub application and still maintain low rolling resistance.

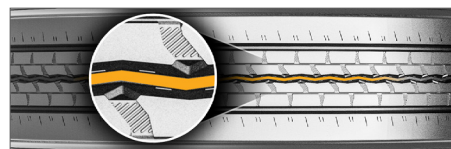

Patented groove technology for minimal stone retention, extending casing life.

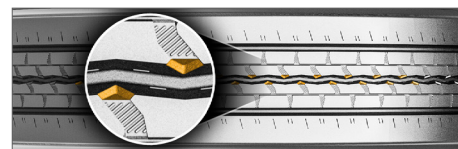

Pyramidal stone ejection system integrated into the center groove for added casing protection.

 **Superior Performance in Spread-axle Trailer Applications vs. HSR2** *Based on projected calculations.

Also available in **19.5" Tire** on pg. 63.

Applications: Spread-axle trailer. Long haul and regional use.

3G Casing	SmartWay® Verified	Intelligent Tire	Retread Available

PRODUCT FEATURES ABOVE ONLY APPLY TO PRODUCTS IF THE MATCHING ICON IS DARKENED.

Conti LAR 3

16" Regional All-Position with Steel Casing

GOODS PEOPLE CONSTRUCTION



REGIONAL

PRODUCT DATA

TIRE SIZE	LOAD RANGE	ARTICLE NUMBER	TREAD DEPTH (32nds)	MAX SPEED (MPH)	STATIC LOADED RADIUS		OVERALL INFLATED DIAMETER		OVERALL INFLATED WIDTH		LOADED SECTION WIDTH		APPROVED RIM(S)	MINIMUM DUAL SPACING		REVS PER UNIT		TIRE WEIGHT		MAX. LOAD @ INFLATION			
					IN	MM	IN	MM	IN	MM	IN	MM		IN	MM	IN	MM	MI	KM	LB	KG	LBS, PSI (KG, KPa)	LBS, PSI (KG, KPa)
LT215/85R16	E	04120940000	14	93	14.3	364	30.6	776	8.9	226	9.6	244	6.00	10.1	258	678	421	53	24	2680, 80 (1215, 550)	2470, 80 (1120, 550)		
LT225/75R16	E	04120950000 # 04650140000 #	14	93	13.9	352	29.7	754	8.9	225	9.5	242	6.00	10.0	254	697	433	52	24	2680, 80 (1215, 550)	2470, 80 (1120, 550)		
LT235/85R16	E	04120960000	14	93	14.4	366	30.9	786	9.9	251	10.6	270	7.00	11.0	279	669	416	56	25	3085, 80 (1400, 550)	2755, 80 (1250, 550)		
LT245/75R16	E	04120970000	14	93	14.4	366	30.9	786	9.9	251	10.6	270	7.00	11.0	279	669	416	56	25	3085, 80 (1400, 550)	2755, 80 (1250, 550)		

TUBELESS TIRES ON 15 DEGREE DROP CENTER RIMS

Note - Rim listed first is the measuring rim. # = Intelligent Tire Article #. Minimum Dual Spacing calculated without chains. # - Exceeding the lawful speed limit is neither recommended nor endorsed. Overall widths will change 0.1 inch (2.5 mm) for each 1/4 inch change in rim width. Minimum dual spacing should be adjusted accordingly. Continental Tire the Americas, LLC reserves the right to change product specifications at any time without notice or obligations. Please consult rim manufacturers load and inflation limits. Never exceed rim manufacturers limits without permission of component manufacturer.

Features & Benefits



All steel radial designed for outstanding durability and maximum retreadability.

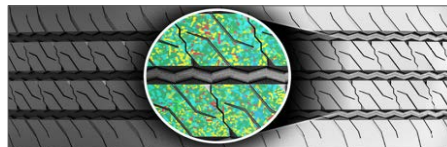

Specialized compounding delivers outstanding mileage while still providing excellent fuel efficiency.



10 ply light truck all steel casing provides increased load carrying capacity, durability and puncture resistance.

Applications: Regional haul, all-position.

			
3G Casing	SmartWay® Verified	Intelligent Tire	Retread Available

PRODUCT FEATURES ABOVE ONLY APPLY TO PRODUCTS IF THE MATCHING ICON IS DARKENED.

LSR1

17.5" Regional All-Position

 GOODS  PEOPLE  CONSTRUCTION



PRODUCT DATA

TIRE SIZE	LOAD RANGE	ARTICLE NUMBER	TREAD DEPTH (32nds)	MAX SPEED (MPH)	STATIC LOADED RADIUS		OVERALL INFLATED DIAMETER		OVERALL INFLATED WIDTH		LOADED SECTION WIDTH		APPROVED RIM(S)	MINIMUM DUAL SPACING		REVS PER UNIT		TIRE WEIGHT		MAX. LOAD @ INFLATION	
					IN	MM	IN	MM	IN	MM	IN	MM		IN	MM	MI	KM	LB	KG	LBS, PSI (KG, KPa)	LBS, PSI (KG, KPa)
10R17.5	H	04121950000	17	75	15.7	398	33.8	858	10.0	254	10.3	262	7.50, 6.75	11.3	286	613	381	70	32	4675, 115 (2120, 790)	4410, 115 (2000, 790)

TUBELESS TIRES ON 15 DEGREE DROP CENTER RIMS

Note - Rim listed first is the measuring rim. Minimum Dual Spacing calculated without chains. # - Exceeding the lawful speed limit is neither recommended nor endorsed. Overall widths will change 0.1 inch (2.5 mm) for each 1/4 inch change in rim width. Minimum dual spacing should be adjusted accordingly. Continental Tire the Americas, LLC reserves the right to change product specifications at any time without notice or obligations. Please consult rim manufacturers load and inflation limits. Never exceed rim manufacturers limits without permission of component manufacturer.

Features & Benefits



Multi-rib tread design features excellent wet traction, lateral stability and reduced noise.

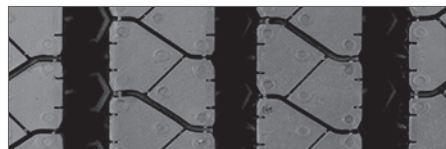

Patented innovative groove technology leads to minimum stone retention, extending casing life.

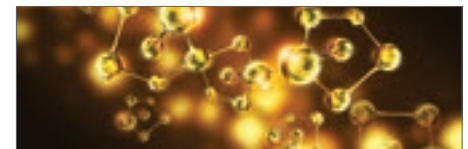

Advanced tread compound provides long original mileage in regional applications.

Applications: Regional and urban all-position use.

			
3G Casing	SmartWay® Verified	Intelligent Tire	Retread Available

PRODUCT FEATURES ABOVE ONLY APPLY TO PRODUCTS IF THE MATCHING ICON IS DARKENED.

HTR2

17.5" Heavy Trailer, Regional

 GOODS  PEOPLE  CONSTRUCTION



REGIONAL

PRODUCT DATA

TIRE SIZE	LOAD RANGE	ARTICLE NUMBER	TREAD DEPTH (32nds)	MAX SPEED (MPH)	STATIC LOADED RADIUS		OVERALL INFLATED DIAMETER		OVERALL INFLATED WIDTH		LOADED SECTION WIDTH		APPROVED RIM(S)	MINIMUM DUAL SPACING		REVS PER UNIT		TIRE WEIGHT		MAX. LOAD @ INFLATION	
					IN	MM	IN	MM	IN	MM	IN	MM		IN	MM	MI	KM	LB	KG	LBS, PSI (KG, KPa)	LBS, PSI (KG, KPa)
					SINGLE		DUAL														
215/75R17.5	H	04920350000	16	68	14.1	359	30.2	767	8.3	211	8.6	218	6.00, 6.75	9.4	239	688	427	60	27	4805, 125 (2180, 860)	4540, 125 (2060, 860)
235/75R17.5	H	04920360000	16	68	14.7	373	31.4	797	9.2	233	9.5	242	6.75, 7.50	10.3	262	662	412	72	33	6005, 125 (2725, 860)	5675, 125 (2575, 860)

TUBELESS TIRES ON 15 DEGREE DROP CENTER RIMS

Note - Rim listed first is the measuring rim. ## = Intelligent Tire Article #. Minimum Dual Spacing calculated without chains. # - Exceeding the lawful speed limit is neither recommended nor endorsed. Overall widths will change 0.1 inch (2.5 mm) for each 1/4 inch change in rim width. Minimum dual spacing should be adjusted accordingly. Continental Tire the Americas, LLC reserves the right to change product specifications at any time without notice or obligations. Please consult rim manufacturers load and inflation limits. Never exceed rim manufacturers limits without permission of component manufacturer.

Features & Benefits

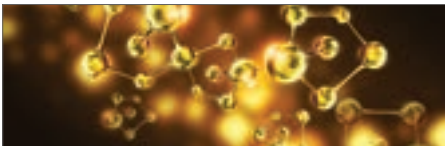

Robust tread compound engineered to protect against cutting and chipping.



Innovative groove geometry designed to prevent stone retention and drilling.

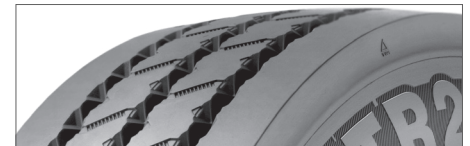

Wide tread and shoulder ribs for improved wear and increased scuff resistance.

Also available in **19.5" Tire** on pg. 48.

Applications: Trailer and pusher positions.

			
3G Casing	SmartWay® Verified	Intelligent Tire	Retread Available

PRODUCT FEATURES ABOVE ONLY APPLY TO PRODUCTS IF THE MATCHING ICON IS DARKENED.

Conti HSR 5

19.5" Regional All-Position

GOODS PEOPLE CONSTRUCTION



PRODUCT DATA



TIRE SIZE	LOAD RANGE	ARTICLE NUMBER	TREAD DEPTH (32nds)	MAX SPEED (MPH)	STATIC LOADED RADIUS		OVERALL INFLATED DIAMETER		OVERALL INFLATED WIDTH		LOADED SECTION WIDTH		APPROVED RIM(S)	MINIMUM DUAL SPACING		REVS PER UNIT		TIRE WEIGHT		MAX. LOAD @ INFLATION	
					IN	MM	IN	MM	IN	MM	IN	MM		IN	MM	MI	KM	LB	KG	LBS, PSI (KG, KPa)	LBS, PSI (KG, KPa)
225/70R19.5	G	05124460000 #05655060000	16	87	15.1	383	32.0	813	8.6	218	9.3	236	6.00, 6.75	10.0	254	647	402	60	28	3970, 110 (1800, 760)	3750, 110 (1700, 760)
225/70R19.5 Coming Soon	H	05128420000 #05655090000	16	87	15.1	384	32.0	813	8.6	218	9.3	236	6.75	10.0	254	647	402	62.5	29	4190, 120 (1900, 830)	3970, 120 (1800, 830)

TUBELESS TIRES ON 15 DEGREE DROP CENTER RIMS

Note - Rim listed first is the measuring rim. Minimum Dual Spacing calculated without chains. # - Exceeding the lawful speed limit is neither recommended nor endorsed. Overall widths will change 0.1 inch (2.5 mm) for each 1/4 inch change in rim width. Minimum dual spacing should be adjusted accordingly. Continental Tire the Americas, LLC reserves the right to change product specifications at any time without notice or obligations. Please consult rim manufacturers load and inflation limits. Never exceed rim manufacturers limits without permission of component manufacturer.

Features & Benefits

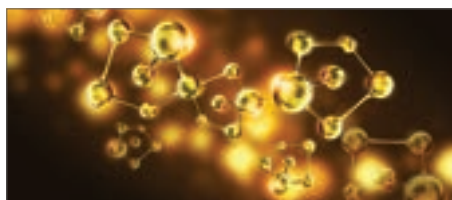

New tread compound delivers **improved rolling resistance and durability**.



Designed with full width siping for **improved traction and handling** during life of the tire.



Developed to provide **excellent lateral stability** to minimize squirm and improve handling.



This product is 3PMSF Certified.



This product is Mud + Snow Certified.

Applications: Long haul/Regional over the highway all-position use.

			
3G Casing	SmartWay® Verified	Intelligent Tire	Retread Available

PRODUCT FEATURES ABOVE ONLY APPLY TO PRODUCTS IF THE MATCHING ICON IS DARKENED.

Conti Hybrid HS3

19.5" Regional All-Position

 GOODS  PEOPLE  CONSTRUCTION



REGIONAL

PRODUCT DATA

TIRE SIZE	LOAD RANGE	ARTICLE NUMBER	TREAD DEPTH (32nds)	MAX SPEED (MPH)	STATIC LOADED RADIUS		OVERALL INFLATED DIAMETER		OVERALL INFLATED WIDTH		LOADED SECTION WIDTH		APPROVED RIM(S)	MINIMUM DUAL SPACING		REVS PER UNIT		TIRE WEIGHT		MAX. LOAD @ INFLATION	
					IN	MM	IN	MM	IN	MM	IN	MM		IN	MM	MI	KM	LB	KG	LBS, PSI (KG, KPa)	LBS, PSI (KG, KPa)
245/70R19.5	G	05122970000	16	81	15.2	386	32.8	833	9.5	241	10.3	262	6.75, 7.50	11.0	279	631	392	78	35	4540, 110 (2060, 760)	4300, 110 (1950, 760)
245/70R19.5	H	05111130000	16	81	15.2	386	32.8	833	9.5	241	10.3	262	6.75, 7.50	11.0	279	631	392	78	35	4940, 120 (2240, 830)	4675, 120 (2120, 830)
265/70R19.5	G	05124840000	17	81	15.8	401	34.7	881	10.3	262	10.7	272	7.50, 6.75, 8.25	11.2	286	613	380	82	37	5510, 115 (2500, 790)	5205, 115 (2360, 790)
285/70R19.5	H	05124810000	18	81	16.2	412	35.9	911	11.1	283	11.6	294	8.25, 7.50, 9.00	12.5	318	590	366	93	42	6610, 125 (3000, 860)	6175, 125 (2800, 860)

TUBELESS TIRES ON 15 DEGREE DROP CENTER RIMS

Note - Rim listed first is the measuring rim. Minimum Dual Spacing calculated without chains. # - Exceeding the lawful speed limit is neither recommended nor endorsed. Overall widths will change 0.1 inch (2.5 mm) for each 1/4 inch change in rim width. Minimum dual spacing should be adjusted accordingly. Continental Tire the Americas, LLC reserves the right to change product specifications at any time without notice or obligations. Please consult rim manufacturers load and inflation limits. Never exceed rim manufacturers limits without permission of component manufacturer.

Features & Benefits



Two-layer tread construction combines high mileage performance in the cap compound with significant rolling resistance improvements in the base compound.



Narrowed groove widths result in increased pattern volume which improves wear resistance to guarantee high mileage performance.

Pocket sipe technology with full-depth sipes to enhance water displacement and improve wet performance over the life of the tire.

Applications: Long haul/Regional over the highway all-position use.

			
3G Casing	SmartWay® Verified	Intelligent Tire	Retread Available

PRODUCT FEATURES ABOVE ONLY APPLY TO PRODUCTS IF THE MATCHING ICON IS DARKENED.

Conti HDR 5

19.5" Regional Drive

 GOODS  PEOPLE  CONSTRUCTION

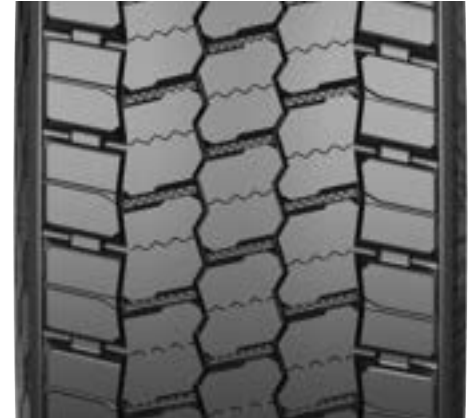

PRODUCT DATA



TIRE SIZE	LOAD RANGE	ARTICLE NUMBER	TREAD DEPTH (32nds)	MAX SPEED (MPH)	STATIC LOADED RADIUS		OVERALL INFLATED DIAMETER		OVERALL INFLATED WIDTH		LOADED SECTION WIDTH		APPROVED RIM(S)	MINIMUM DUAL SPACING		REVS PER UNIT		TIRE WEIGHT		MAX. LOAD @ INFLATION	
					IN	MM	IN	MM	IN	MM	IN	MM		IN	MM	IN	MM	MI	KM	LB	KG
225/70R19.5	G	05223820000 # 05652850000	16	87	15.1	383	32.0	814	8.6	219	9.3	236	6.00, 6.75	10.0	254	646	401	61	28	3970, 110 (1800, 760)	3750, 110 (1700, 760)
225/70R19.5 Coming Soon	H	05225820000 # 05655080000	16	87	15.1	384	32.0	813	8.6	218	9.3	236	6.75	10.0	254	647	402	62.5	29	4190, 120 (1900, 830)	3970, 120 (1800, 830)

TUBELESS TIRES ON 15 DEGREE DROP CENTER RIMS

Note - Rim listed first is the measuring rim. ## = Intelligent Tire Article #. Minimum Dual Spacing calculated without chains. # - Exceeding the lawful speed limit is neither recommended nor endorsed. Overall widths will change 0.1 inch (2.5 mm) for each 1/4 inch change in rim width. Minimum dual spacing should be adjusted accordingly. Continental Tire the Americas, LLC reserves the right to change product specifications at any time without notice or obligations. Please consult rim manufacturers load and inflation limits. Never exceed rim manufacturers limits without permission of component manufacturer.

Features & Benefits

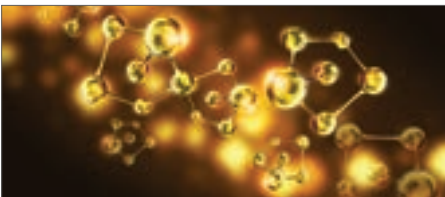

New tread compound for **improved rolling resistance and tread durability.**

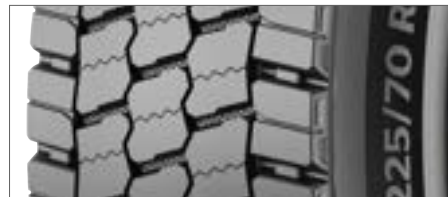

New **open shoulder** tread design.

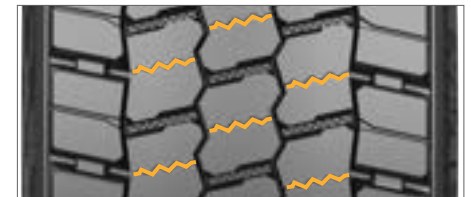

3D matrix siping for **improved traction and wear** over life of tire.



Tread pattern designed to deliver **M+S (Mud and Snow)** and **3PMSF (Three Peak Mountain Snowflake)** for demanding conditions.



16/32* tread pattern designed to deliver **improved mileage and handling** performance.



This product is 3PMSF Certified.



This product is Mud + Snow Certified.

Applications: Long haul/Regional over the highway drive use.

			
3G Casing	SmartWay® Verified	Intelligent Tire	Retread Available

PRODUCT FEATURES ABOVE ONLY APPLY TO PRODUCTS IF THE MATCHING ICON IS DARKENED.

Conti Hybrid HD3

19.5" Regional Drive

 GOODS  PEOPLE  CONSTRUCTION

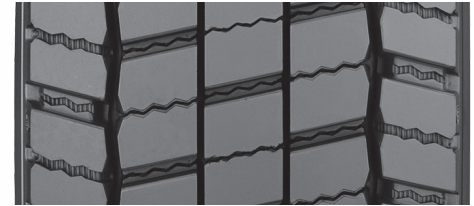

PRODUCT DATA



TIRE SIZE	LOAD RANGE	ARTICLE NUMBER	TREAD DEPTH (32nds)	MAX SPEED (MPH)	STATIC LOADED RADIUS		OVERALL INFLATED DIAMETER		OVERALL INFLATED WIDTH		LOADED SECTION WIDTH		APPROVED RIM(S)	MINIMUM DUAL SPACING		REVS PER UNIT		TIRE WEIGHT		MAX. LOAD @ INFLATION	
					IN	MM	IN	MM	IN	MM	IN	MM		IN	MM	IN	MM	MI	KM	LB	KG
245/70R19.5	G	05222240000	19	81	15.5	393	33.2	843	9.7	246	10.3	263	7.50, 6.75	11.0	279	623	387	82	37	4540, 110 (2060, 760)	4300, 110 (1950, 760)
245/70R19.5	H	05210830000	19	81	15.5	393	33.2	843	9.7	246	10.3	263	7.50, 6.75	11.0	279	623	387	82	37	4940, 120 (2240, 830)	4675, 120 (2120, 830)
265/70R19.5 (Tread B)	G	05225540000 *05653840000*	20	81	15.8	401	34.7	881	10.3	262	10.7	272	7.50, 6.75, 8.25	11.2	286	613	381	86	39	5510, 115 (2500, 790)	5205, 115 (2360, 790)
285/70R19.5 (Tread B)	H	05220880000	20	81	16.2	412	35.9	911	11.1	283	11.6	294	8.25, 7.50, 9.00	12.5	318	590	366	97	44	6610, 125 (3000, 860)	6175, 125 (2800, 860)

TUBELESS TIRES ON 15 DEGREE DROP CENTER RIMS

Note - Rim listed first is the measuring rim. * = Intelligent Tire Article #. Minimum Dual Spacing calculated without chains. # - Exceeding the lawful speed limit is neither recommended nor endorsed. Overall widths will change 0.1 inch (2.5 mm) for each 1/4 inch change in rim width. Minimum dual spacing should be adjusted accordingly. Continental Tire the Americas, LLC reserves the right to change product specifications at any time without notice or obligations. Please consult rim manufacturers load and inflation limits. Never exceed rim manufacturers limits without permission of component manufacturer.

Features & Benefits



Advanced application-optimized **Hybrid tread compound** adds up to significant improvements in rolling resistance and mileage.

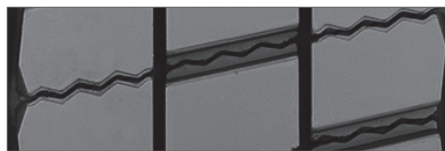

Narrowed groove widths result in increased pattern volume which improves wear resistance to guarantee high mileage performance.

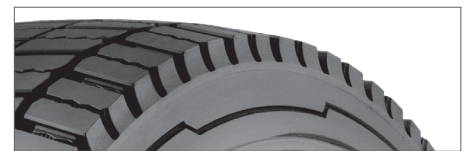

Chamfered Edge reduces deformation amplitude in sidewall and bead area which results in improved rolling resistance and helps lower fuel consumption.



This product is Mud + Snow Certified.

Also available in **22.5" Tire** on pg. 52.

Applications: Long haul/Regional over the highway drive use.

			
3G Casing	SmartWay® Verified	Intelligent Tire	Retread Available

PRODUCT FEATURES ABOVE ONLY APPLY TO PRODUCTS IF THE MATCHING ICON IS DARKENED.

Conti Scandinavia HD3

19.5" Regional Drive for Extreme Weather Conditions

 GOODS  PEOPLE  CONSTRUCTION



PRODUCT DATA



TIRE SIZE	LOAD RANGE	ARTICLE NUMBER	TREAD DEPTH (32nds)	MAX SPEED (MPH)	STATIC LOADED RADIUS		OVERALL INFLATED DIAMETER		OVERALL INFLATED WIDTH		LOADED SECTION WIDTH		APPROVED RIM(S)	MINIMUM DUAL SPACING		REVS PER UNIT		TIRE WEIGHT		MAX. LOAD @ INFLATION	
					IN	MM	IN	MM	IN	MM	IN	MM		IN	MM	MI	KM	LB	KG	LBS, PSI (KG, KPa)	LBS, PSI (KG, KPa)
					SINGLE		DUAL														
225/70R19.5	G	05230340000	19	87	15.1	383	32.0	813	8.6	218	9.3	236	6.00, 6.75	10.0	254	647	402	65	30	3970, 110 (1800, 760)	3750, 110 (1700, 760)
245/70R19.5	H	05230360000	21	81	15.5	394	33.3	846	9.5	241	10.4	264	7.50, 6.75	11.0	279	622	386	80	36	4940, 120 (2240, 830)	4675, 120 (2120, 830)

TUBELESS TIRES ON 15 DEGREE DROP CENTER RIMS

Note - Rim listed first is the measuring rim. Minimum Dual Spacing calculated without chains. # - Exceeding the lawful speed limit is neither recommended nor endorsed. Overall widths will change 0.1 inch (2.5 mm) for each 1/4 inch change in rim width. Minimum dual spacing should be adjusted accordingly. Continental Tire the Americas, LLC reserves the right to change product specifications at any time without notice or obligations. Please consult rim manufacturers load and inflation limits. Never exceed rim manufacturers limits without permission of component manufacturer.

Features & Benefits



Deep tread and low void design ensures long removal miles.

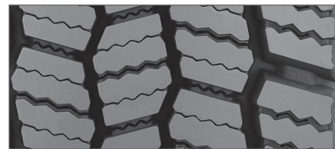

Heavy siping provides **numerous gripping edges** for excellent traction on wet roads.



Open shoulder tread design for increased traction in snow.

Increased footprint contact area delivers superior traction and stability.



All season compound to deliver excellent traction in all weather conditions without sacrificing removal miles.



This product is Mud + Snow Certified.

Also available in **22.5" & 24.5" Tire** on pg. 51.

Applications: Drive axle tire for extreme weather conditions.

			
3G Casing	SmartWay® Verified	Intelligent Tire	Retread Available

PRODUCT FEATURES ABOVE ONLY APPLY TO PRODUCTS IF THE MATCHING ICON IS DARKENED.

Conti Hybrid HT3

19.5" Regional Trailer

 GOODS  PEOPLE  CONSTRUCTION



PRODUCT DATA

TIRE SIZE	LOAD RANGE	ARTICLE NUMBER	TREAD DEPTH (32nds)	MAX SPEED (MPH)	STATIC LOADED RADIUS		OVERALL INFLATED DIAMETER		OVERALL INFLATED WIDTH		LOADED SECTION WIDTH		APPROVED RIM(S)	MINIMUM DUAL SPACING		REVS PER UNIT		TIRE WEIGHT		MAX. LOAD @ INFLATION	
					IN	MM	IN	MM	IN	MM	IN	MM		IN	MM	IN	MM	MI	KM	LB	KG
265/70R19.5	H	05322000000	17	68	15.8	401	34.7	881	10.3	262	10.7	272	7.50, 6.75, 8.25	11.6	295	609	378	80	36	6005, 125 (2725, 860)	5675, 125 (2575, 860)
285/70R19.5	J	05321680000	18	68	16.2	412	35.9	911	11.1	283	11.6	294	8.25, 7.50, 9.00	12.5	318	590	366	93	42	7390, 130 (3350, 900)	6940, 130 (3150, 900)

TUBELESS TIRES ON 15 DEGREE DROP CENTER RIMS

Note - Rim listed first is the measuring rim. Minimum Dual Spacing calculated without chains. # - Exceeding the lawful speed limit is neither recommended nor endorsed. Overall widths will change 0.1 inch (2.5 mm) for each 1/4 inch change in rim width. Minimum dual spacing should be adjusted accordingly. Continental Tire the Americas, LLC reserves the right to change product specifications at any time without notice or obligations. Please consult rim manufacturers load and inflation limits. Never exceed rim manufacturers limits without permission of component manufacturer.

Features & Benefits



Advanced application-optimized compound adds up to significant improvements in rolling resistance and mileage.

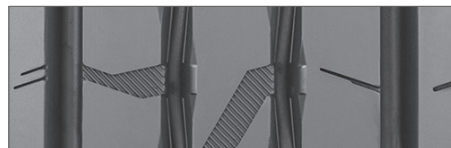

Narrowed groove widths result in increased pattern volume which improves wear resistance to provide high mileage performance.



Low rolling resistance sidewall compound used to reduce heat through friction elimination.

Also available in **22.5" & 24.5" Tire** on pg. 54.

Applications: Long haul/Regional over the highway trailer use.



CONTINENTAL IS YOUR LEADER IN FUEL EFFICIENCY

Continental Tires Outperformed Other Top Brands in Fuel Efficiency Tests

Pumping Out Savings Tractors travel an average of **105,000 miles** every year. With a national average of 5.91 mpg, every tractor burns **over 17,700 gallons of fuel a year**. At \$3.89/gallon, **that's over \$69,000 in annual fuel costs!** With **Continental's demonstrated 7.26 mpg fuel efficiency** in Regional testing, fleets could achieve **an annual costs savings of over \$12,800 per truck!***

*Savings calculations based on "NACFE 2018 Annual Fleet Fuel Study" by the North American Council for Fuel Efficiency

Regional Tires Selected for Test



Conti HSL 3
(Rename of Conti Hybrid HS3)
Regional Haul
11R22.5 | G | 16/32"

HDR2 Eco Plus
Regional Haul
11R22.5 | G | 30/32"

Conti Hybrid HT3
Regional Haul
11R22.5 | G | 16/32"

About Regional Tires

Tires for Regional use are designed for applications where vehicles spend the majority of their time on pavement with multiple stops through inter-city operations, and mostly paved roads. Tires are optimized for high scrub, cut-chip resistance applications as well as traction. To put our level of fuel efficiency to the test, Continental tires were used in a study by the PIT Group of FPIInnovations.

Regional Haul Application Test Results

Tires	Double Coin	Continental	Michelin
Steer Tire	RT606+	Conti HSL 3 (Conti Hybrid HS3)	XZE2
Drive Tire	RLB1	HDR2 Eco Plus	XDN2
Trailer Tire	RR150	Conti Hybrid HT3	XZE2
Fuel consumption (L/100 km)	34.29	32.41	34.58
Fuel economy (mpg)	6.86	7.26	6.80
Rank	2	1	3

In Regional applications, *Continental is proven to provide a 6.27% savings* compared to Michelin.

The Test

The fuel efficiency test procedure was based on TMC Fuel Consumption Test Procedure - Type III, RP 1103A. Each tire brand was tested on three identical 2016 International Prostar tractors powered by Cummins ISX15 engines, pulling 2018 Vanguard 53-foot two-axle cube van semi-trailers, at a cruising speed of 64.6 mph (104 km/h).

CONTINENTAL DELIVERS UP TO
6% FUEL SAVINGS
OVER OTHER TOP BRANDS

Contact your Continental representative to learn more!

Need a representative? Call 1 (800) 450-3187





Regional Retread Product Overview

For Highway & Local Driving

Legend:



HSR 5 (19.5")
 



HSR 3
 



HSR - 18/32"
 

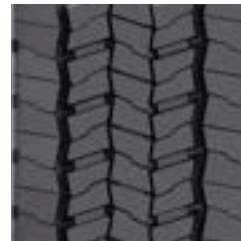

HSR - 16/32"
 

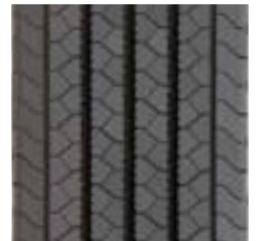

LSR1
 

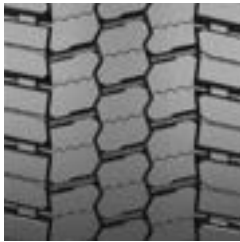

HDR 5 (19.5")
 

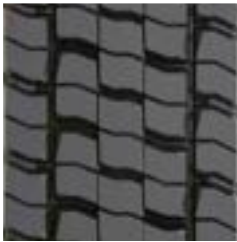

HDR2
 



HDR1
 



HDR1 Eco Plus
 



Scandinavia HD3
 



HDW2
 



Hybrid HT3
 



HTR2 SA
 



HTR2
 



Legend:



SmartWay® Verified New Tire Available

ContiTread™ HSR 3 | Regional All-Position





PRODUCT DATA		 
WIDTH (MM)	ARTICLE NUMBER	TREAD DEPTH (32nds)
190	18217850000	20
200	18217860000	20
210	18217870000	20
220	18217880000	20
230	18217890000	20
240	18217900000	20

- Zigzag center groove geometry increases the number of biting edges for increased traction.
- Pyramidal stone ejectors in all tread grooves to stop stone retention for long casing life.
- Durable compounding for mileage.

ContiTread™ HSR - 16/32" | 19.5" Regional All-Position





PRODUCT DATA		 
WIDTH (MM)	ARTICLE NUMBER	TREAD DEPTH (32nds)
180	18310030000	16
195	18310460000	16

- 16/32" cut and chip resistant tread for long tread life.
- Aggressive tread design provides excellent lateral stability to minimize squirm, and improve wet handling performance.
- Closed shoulder to protect against curbing, cuts and abrasions.

ContiTread™ HSR - 18/32" | Regional All-Position





PRODUCT DATA		 
WIDTH (MM)	ARTICLE NUMBER	TREAD DEPTH (32nds)
195	18207940000	18
215	18204780000	18
225	18204790000	18
235	18204800000	18
245	18204810000	18
260	18310610000	18

- Cut and chip resistant tread for long tread life.
- Pyramidal stone ejectors in all tread grooves to stop stone retention for long casing life.
- Robust shoulder rib for long tread life.

ContiTread™ HSR 5 | 19.5" Regional Steer Position



PRODUCT DATA		 
WIDTH (MM)	ARTICLE NUMBER	TREAD DEPTH (32nds)
200	18219600000	16
210	18219610000	16

- Tread compound designed to provide longer life in regional applications.
- Tread pattern and siping provides excellent wet/dry traction, and resists irregular wear.
- Narrow width for 19.5" casings.

Legend:



ContiTread™ LSR1 | 17.5" Regional All-Position

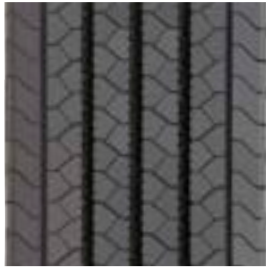

PRODUCT DATA		
WIDTH (MM)	ARTICLE NUMBER	TREAD DEPTH (32nds)
160	18206070000	15
180	18206080000	15
188	18206090000	15
195	18206100000	15
205	18207890000	15

- Advanced tread compound provides high mileage in regional applications.
- Multi-rib tread design features excellent wet traction, lateral stability and reduced noise.
- Unique pyramid shaped stone ejection system in all tread grooves reduce stone retention and casing penetrations.

ContiTread™ HDR2 | Regional Drive

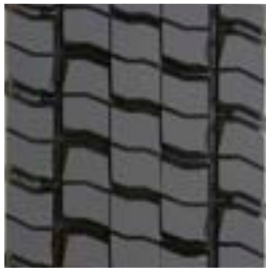

PRODUCT DATA		
WIDTH (MM)	ARTICLE NUMBER	TREAD DEPTH (32nds)
185	18215760000	22
195	18215770000	22
205	18215780000	22
215	18215790000	22
225	18215800000	22
235	18215810000	22
245	182157820000	22

- Cut and tear resistance tread compound for excellent wear in regional and light On/Off applications.
- Optimal performance on various road conditions, through an innovative tread compound.
- Unidirectional, arrow shaped tread pattern minimizes typical drive tire wear effects.

ContiTread™ HDR 5 | 19.5" Regional Drive

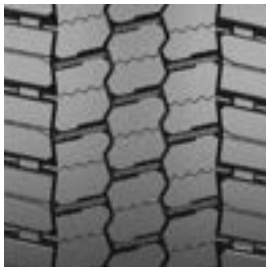

PRODUCT DATA		
WIDTH (MM)	ARTICLE NUMBER	TREAD DEPTH (32nds)
200	18219620000	22
210	18219630000	22
220	18219640000	22

- Cut and tear resistant tread compound for excellent wear in regional applications.
- Open shoulder tread design along with advanced siping provides excellent wet/dry traction, and resists irregular wear.
- Narrow width for 19.5 casings.



ContiTread™ HDR1 | Regional Drive



PRODUCT DATA		
WIDTH (MM)	ARTICLE NUMBER	TREAD DEPTH (32nds)
160	18215600000	16
170	18215610000	16
180	18215620000	16
190	18215630000	16
200	18215640000	16
215	18215650000	16
190	18215660000	20
200	18215670000	20
235	18215700000	22
215	18215720000	26
225	18215730000	26
235	18215740000	26
245	18215750000	26

- Cut and tear resistant tread compound for excellent wear in regional and light On/Off applications.
- Open shoulder tread design provides excellent wet/dry traction, resists irregular wear and reduces stone retention.
- Innovative lug angle provides outstanding traction throughout the life of the tread.

ContiTread™ HDR1 Eco Plus | Regional Drive



PRODUCT DATA		
WIDTH (MM)	ARTICLE NUMBER	TREAD DEPTH (32nds)
215	18207700000	22
225	18207710000	22
235	18207720000	22

- Advanced, fuel efficient compound provides long original mileage and rolling resistance.
- Open shoulder tread design provides excellent wet/dry traction, resists irregular wear and reduces stone retention.
- Innovative lug angle provides outstanding traction throughout the life of the tread.

ContiTread™ Scandinavia HD3 Regional Drive for Extreme Weather Conditions



PRODUCT DATA		
WIDTH (MM)	ARTICLE NUMBER	TREAD DEPTH (32nds)
210	18211340000	25
220	18211350000	25
230	18211360000	25
240	18211370000	25

- Directional* tread pattern for improved traction.
- Full sipes located on center ribs in center grooves at 22/32" for improved snow evacuation.
- Pocket sipes featured throughout the tread pattern at 13/32"
- Optimized groove geometry for stone trapping resistance.
- Tie bars included to improve wear mileage near end of life.



Legend:



ContiTread™ HDW2 | Regional Drive for Extreme Weather Conditions





Tread B

PRODUCT DATA			 
WIDTH (MM)	ARTICLE NUMBER	TREAD DEPTH (32nds)	
215	18209370000	27	<ul style="list-style-type: none"> • High-mileage compound • All season tread ensures optimum performance in a variety of winter conditions from ice to snow. • Directional* tread design with more than 1,000 sipes provides excellent traction and lateral stability in 245 and 260 mm sizes.
225	18209380000	27	
235	18209390000	27	
245 (Tread B)	18209400000	27	
260 (Tread B)	18209410000	27	



ContiTread™ Hybrid HT3 | Regional Trailer for Spread-Axle



PRODUCT DATA			 
WIDTH (MM)	ARTICLE NUMBER	TREAD DEPTH (32nds)	
200	18214620000	16	<ul style="list-style-type: none"> • New and improved winged tread for use in high scrub applications, particularly spread-axle and multi-axle. • Durable high mileage compounding. • Pyramidal stone ejection system integrated into the center groove for added casing protection.
210	18214630000	16	
220	18214640000	16	
230	18214650000	16	



ContiTread™ HTR2 SA | Regional Trailer for Spread-Axle



PRODUCT DATA			 
WIDTH (MM)	ARTICLE NUMBER	TREAD DEPTH (32nds)	
240	18207560000	16	<ul style="list-style-type: none"> • Winged tread for use in high scrub applications, particularly spread-axle and multi-axle. • High mileage achieved through precise balance of tread compound and geometry.
250	18207570000	16	
260	18207580000	16	
270	18207590000	16	
290	18207600000	16	

ContiTread™ HTR2 | Regional Trailer



PRODUCT DATA			 
WIDTH (MM)	ARTICLE NUMBER	TREAD DEPTH (32nds)	
290	18206730000	22	<ul style="list-style-type: none"> • High mileage achieved through precise balance of tread compound and geometry. • Tread pattern designed for increased stability and reduced noise. • Patented innovative groove technology leads to minimum stone retention.
320	18206740000	22	
340	18206750000	22	

Digital Tire Monitoring Solutions

Increasing Uptime, Decreasing Costs

Why invest in tire pressure & temperature monitoring?

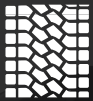

Improve Tire Runout

Minimize irregular wear, one of the primary reasons for early tire removal.



Save Fuel

How much do you spend per month on fuel? What would 1% savings mean to your bottom line?



Save Labor and Tire Maintenance Costs

Reduce time spent on manual tire pressure checks and repairing tire issues caused by underinflation.



Reduce Roadside Breakdowns

Avoid downtime, late deliveries, and cost of approximately \$800 per incident.



Improve Safety

Help protect your drivers and other road users.

Properly inflated tires can reduce total tire-related costs by \$600 to \$800 annually per vehicle.

Actual results may vary. According to the Technology & Maintenance Council (TMC) S-2 Tire & Wheel Study Group, improper tire inflation, defined as little as 10 psi low, reduces fuel economy by about one percent, increases total tire-related costs by approximately \$600 to \$800 annually per tractor-trailer combination, and changes the tire contact patch which affects stopping and acceleration traction and vehicle handling thereby impacting vehicle safety.



Benefits of the Intelligent Tire | Equipped with TPMS Sensor

- **Accurate, real-time tire pressure and temperature** to prevent tire damage and breakdowns
- **Sensor warranted for 5 years*** to minimize disruptions to your tire program
- **Provides true tire casing temperature**, allowing preventive actions that make your tire last longer.
- **Avoids valve damage and air leaks** by mounting on the inner liner of the tire

*See Warranty Policy for details.

Intelligent Tires are ready to pair with the following solutions:

ContiConnect Yard

Digital Tire Monitoring with Web Portal

- **Mounted in the fleet terminal** and reads sensors in a 65-foot radius*
- **Mobile-friendly web portal** displays tire data for all vehicles
- **Text & email notifications** can alert fleet personnel of detected issues
- **Ideal for vehicles that return to the fleet yard** at least once per week

*Operating radius may be affected by various factors including obstructions.

ContiConnect LIVE | Real-time Monitoring

- **Ideal for real-time monitoring** of multiple-vehicles in any location
- **TPMS + GPS** for more precise data
- **Actionable data** even when vehicles are out on the road
- **Instantaneous alerts** at fleet, dispatch, and driver level
- **Seamless monitoring** of drop-and-hook as well as married tractor-trailers

ContiConnect LIVE | Trailer Monitoring

- **Continuous** trailer monitoring
- **TPMS + GPS** for more precise data
- **Built-in battery** to check in when not connected to a power unit
- **Know your trailer tire conditions** before a driver connects
- **See location** of all trailer assets

ContiPressureCheck | On-Vehicle TPMS

- **Informs the driver in real-time** via a convenient in-cab display
- **Supports multiple trailer configurations:** married and drop-and-hook
- **Ideal for long-haul and over-the-road vehicles** that don't return to the yard frequently

ContiPressureCheck™ Integrated | Remote Tire Monitoring

- **Alerts back-office personnel in real-time** to tire issues on the road
- **Potential for driver alerts** via an optional in-cab display
- **Available with the following telematics providers:**





Hours of Service // Superior Mileage // Durable Cut/Chip Compounding // Casing Durability

Urban

For Inner City Traffic & Short Distances

Engineered for your application. Urban tires are designed for inner city traffic applications where traction, hours of service and mileage are priority. Tires operating within this application normally operate through short distances experiencing heavy scrub. Tires are designed to withstand heat generation as well as heavy loads where safety is essential. Extra sidewall protection is required to protect the casing from curbing, cuts and abrasions. Casing durability is the key aspect for segment satisfaction.

IMPORTANT NOTE: Tire Products are now classified by route. Product details are subject to change, please visit our website or contact your local sales representative for the most up to date information.

Legend:

3G 3G Casing	 SmartWay® Verified	 Intelligent Tire	 Retread Available
------------------------	---	---	--

PRODUCT FEATURES ABOVE ONLY APPLY TO PRODUCTS IF THE MATCHING ICON IS DARKENED.

Urban

Truck Tire Product Overview



Conti Urban HA3
3G   



Conti HAU 3 WT
3G   

			
3G Casing	SmartWay® Verified	Intelligent Tire	Retread Available

PRODUCT FEATURES ABOVE ONLY APPLY TO PRODUCTS IF THE MATCHING ICON IS DARKENED.

Conti Urban HA3

Metro Service All-Position

● GOODS ●  PEOPLE ● CONSTRUCTION



PRODUCT DATA

TIRE SIZE	LOAD RANGE	ARTICLE NUMBER	TREAD DEPTH (32nds)	MAX SPEED (MPH)	STATIC LOADED RADIUS		OVERALL INFLATED DIAMETER		OVERALL INFLATED WIDTH		LOADED SECTION WIDTH		APPROVED RIM(S)	MINIMUM DUAL SPACING		REVS PER UNIT		TIRE WEIGHT		MAX. LOAD @ INFLATION	
					IN	MM	IN	MM	IN	MM	IN	MM		IN	MM	MI	KM	LB	KG	LBS, PSI (KG, KPa)	LBS, PSI (KG, KPa)
305/70R22.5	L	05140860000 #05652900000	23	68	18.6	473	39.9	1014	11.6	294	12.6	320	9.00, 8.25	135	343	519	322	130	59	7830, 130 (3550, 900)	6940, 130 (3150, 900)

TUBELESS TIRES ON 15 DEGREE DROP CENTER RIMS

Note - Rim listed first is the measuring rim. # = Intelligent Tire Article #. Minimum Dual Spacing calculated without chains. These specifications subject to change without notice. # - Exceeding the lawful speed limit is neither recommended nor endorsed. Overall widths will change 0.1 inch (2.5 mm) for each 1/4 inch change in rim width. Minimum dual spacing should be adjusted accordingly. Continental Tire the Americas, LLC reserves the right to change product specifications at any time without notice or obligations. Please consult rim manufacturers load and inflation limits. Never exceed rim manufacturers limits without permission of component manufacturer.

Features & Benefits



Increased sidewall gauge for improved resistance against curbing, cuts and abrasions.

Sidewall wear indicator for visual cue to trigger rotation.

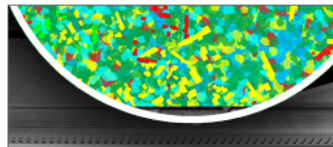

New urban tread compound for prolonged mileage performance with excellent driving characteristics.



Comfortable ride for driver and passengers through extremely quiet running tread.



Durable casing for premium retreadability and enhanced mileage.

Applications: Urban steer/all-position, city bus use.

			
3G Casing	SmartWay® Verified	Intelligent Tire	Retread Available

PRODUCT FEATURES ABOVE ONLY APPLY TO PRODUCTS IF THE MATCHING ICON IS DARKENED.

Conti HAU 3 WT

Urban All-Position for Waste Transport

 GOODS  PEOPLE  CONSTRUCTION



PRODUCT DATA																3G		SmartWay Verified		Intelligent Tire		Retread Available		Truck	
TIRE SIZE	LOAD RANGE	ARTICLE NUMBER	TREAD DEPTH (32nds)	MAX SPEED (MPH)	STATIC LOADED RADIUS		OVERALL INFLATED DIAMETER		OVERALL INFLATED WIDTH		LOADED SECTION WIDTH		APPROVED RIM(S)	MINIMUM DUAL SPACING		REVS PER UNIT		TIRE WEIGHT		MAX. LOAD @ INFLATION					
					IN	MM	IN	MM	IN	MM	IN	MM		IN	MM	MI	KM	LB	KG	LBS, PSI (KG, KPa)	LBS, PSI (KG, KPa)				
315/80R22.5	L	05141090000 #05652550000 #	26	68	20.0	507	43.1	1095	12.4	314	13.8	349	9.00, 8.25*	13.8	351	480	298	167	76	10200, 130 (4540, 900)	9090, 130 (4125, 900)				
PLEASE NOTE: THIS PRODUCT WAS PREVIOUSLY NAMED CONTI CITYSERVICE HA3.																									
TUBELESS TIRES ON 15 DEGREE DROP CENTER RIMS																									
*315/80R22.5 tires used on 8.25" rims are restricted to a maximum of 7610 lbs at 120 psi.																									
<p>Note - Rim listed first is the measuring rim. # = Intelligent Tire Article #. Minimum Dual Spacing calculated without chains. # - Exceeding the lawful speed limit is neither recommended nor endorsed. Overall widths will change 0.1 inch (2.5 mm) for each 1/4 inch change in rim width. Minimum dual spacing should be adjusted accordingly. 315/80R22.5 tires used on 8.25" rims are restricted to a maximum of 7610 lbs at 120 psi. Continental Tire the Americas, LLC reserves the right to change product specifications at any time without notice or obligations. Please consult rim manufacturers load and inflation limits. Never exceed rim manufacturers limits without permission of component manufacturer.</p>																									

Features & Benefits



Four rib tread pattern with zigzag groove geometry for resistance to high scrub applications.

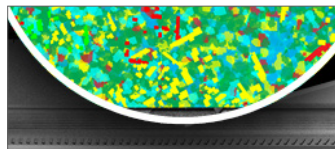

Innovative tread compound for outstanding mileage and heat reduction.



Improved bead design for increased durability and resistance to brake heat.



Extra sidewall protection for better resistance to curbs, cuts, and other sidewall abrasions.

Applications: Waste transportation and other high scrub, urban applications.



Urban Retread Product Overview

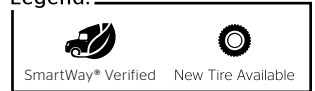

For Inner City Traffic & Short Distances

Legend:



ContiTread™ HAU 3 WT | Urban All-Position for Waste Transport





PRODUCT DATA		 
WIDTH (MM)	ARTICLE NUMBER	TREAD DEPTH (32nds)
210	18217910000	26
220	18217920000	26
230	18217930000	26
240	18217940000	26
250	18217950000	26
260	18217960000	26
270	18217970000	26
280	18217980000	26

- Optimized tread compound for long removal mileage and chip and chunk resistance.
- Robust four rib tread design for increased durability in high scrub applications.
- Zig-zag groove geometry engineered specifically for use in waste transportation.

ContiTread™ HDU 3 WT | Urban Drive for Waste Transport



PRODUCT DATA		 
WIDTH (MM)	ARTICLE NUMBER	TREAD DEPTH (32nds)
210	18217990000	32
220	18218000000	32
230	18218010000	32
240	18218020000	32
250	18218030000	32
260	18218040000	32
270	18218050000	32
280	18218060000	32

- Deep 32/32" tread depth and open shoulder tread design for excellent traction.
- Shoulder notches included in design to prevent heat build-up.
- Chip and chunk resistant compounding for endurance in waste and other high scrub applications.
- Tie bars included to improve wear mileage near end of life.

Conti360°

Continental's Fleet Services Web Portal

Accounting

Easily print or save your Continental invoices for commercial tires in PDF format. You also have the ability to download an Excel version of the list of all invoices and credits in a date range. Financial Statements are accessible for printing or saving, and you have the option of viewing your last month's statement or a real time statement. Also now includes "Dispute Invoice" functionality and dealer Proof of Service Images.

Accessibility

View the Dealer Locator to find your nearest servicing dealer. Log into your ContiConnect® tire monitoring portal if you utilize Continental's digital tire monitoring solutions, such as the ContiConnect Yard Reader. Access business intelligence and tools to keep your fleet at maximum efficiency.

Reporting

With Conti360°, you can gain insight into so many aspects of your fleet. From breakdown analysis to purchases to product performance, our reporting feature is designed to keep you in the know.

Learn more about reporting below.

Ordering

Order Continental's Digital Solutions, including replacement parts, additional tire sensors, and more, directly from the Conti360° Fleet Portal.



Gain access to ContiAcademy, our virtual training platform to learn about Continental products, solutions, and live training opportunities.

www.Conti360Fleet.com - YOUR 24/7 BUSINESS SOLUTION

Conti360° Reporting is designed to keep fleets in the know:

TrukFix

If your fleet participates in Continental's TrukFix roadside breakdown assistance program, you will be able to generate a detailed report of breakdowns, causes, downtime, and more.

ContiTrack2

ContiTrack2 digital tire inspections are performed by your Continental sales representative or dealer. Detailed reports on tire wear, tread depth, and recommendations to improve performance are available for viewing and printing.

CLC-Soft

Fleets who use our ContiLifeCycle partners to retread their casings have the ability to track the progress of the retread. Different types of reports are available for a 360° view.

Sales & Service

Within a specified time period, you have the ability to view product and digital solution purchases, as well as run reports of which services your dealer performed.



Superior Mileage // Durable Cut/Chip Compounding // Resistance to Stone Drilling // Optimal Retreadability

Construction

For Durability On & Off-Road

Engineered for your application. Tires for Construction and On/Off Road use are designed for vocational applications such as utility trucks, concrete mixers, and dump trucks, etc., where they spend some time on the pavement but are also likely to encounter curbs, stones, debris, and tight turns. Tires are optimized for durability and traction, as well as minimal stone retention and cut-and-tear resistance.

IMPORTANT NOTE: Tire Products are now classified by route. Product details are subject to change, please visit our website or contact your local sales representative for the most up to date information.

Legend:

			
3G Casing	SmartWay® Verified	Intelligent Tire	Retread Available

PRODUCT FEATURES ABOVE ONLY APPLY TO PRODUCTS IF THE MATCHING ICON IS DARKENED.

Construction

Truck Tire Product Overview



Conti HSC 3
   



Conti HAC 3
   



Conti HDC 3
   



HDC1 HT
   



HTC
   



CONSTRUCTION

 3G Casing	 SmartWay* Verified	 Intelligent Tire	 Retread Available
--	--	--	---

PRODUCT FEATURES ABOVE ONLY APPLY TO PRODUCTS IF THE MATCHING ICON IS DARKENED.

Conti HSC 3

Intelligent Construction Steer/All-Position

 GOODS  PEOPLE  CONSTRUCTION



PRODUCT DATA

TIRE SIZE	LOAD RANGE	ARTICLE NUMBER	TREAD DEPTH (32nds)	MAX SPEED (MPH)	STATIC LOADED RADIUS		OVERALL INFLATED DIAMETER		OVERALL INFLATED WIDTH		LOADED SECTION WIDTH		APPROVED RIM(S)	MINIMUM DUAL SPACING		REVS PER UNIT		TIRE WEIGHT		MAX. LOAD @ INFLATION	
					IN	MM	IN	MM	IN	MM	IN	MM		IN	MM	MI	KM	LB	KG	LBS, PSI (KG, KPa)	LBS, PSI (KG, KPa)
11R22.5	H	05652440000	24	68	19.6	498	41.7	1060	11.7	297	12.7	322	8.25, 7.50	12.5	318	496	308	135	61	6610, 120 (3000, 830)	6005, 120 (2725, 830)
12R22.5	H	05652460000	24	68	20.1	512	42.9	1090	11.8	301	13.0	329	9.00, 8.25	13.5	343	482	300	150	68	7390, 120 (3350, 830)	6780, 120 (3075, 830)
315/80R22.5	L	05652480000	24	68	19.8	502	42.9	1089	12.5	318	13.8	351	9.00, 8.25	13.8	351	483	300	162	74	10200, 130 (4625, 900)	9090, 130 (4125, 900)
11R24.5	H	05652450000	24	68	20.6	523	43.9	1115	11.7	297	12.7	322	8.25, 7.50	12.5	318	472	293	144	65	7160, 120 (3250, 830)	6610, 120 (3000, 830)
12R24.5	H	05652470000	24	68	21.1	537	44.9	1141	12.0	305	14.5	368	9.00, 8.25	13.7	348	461	286	163	74	7830, 120 (3550, 830)	7160, 120 (3250, 830)

TUBELESS TIRES ON 15 DEGREE DROP CENTER RIMS

*315/80R22.5 tires used on 8.25" rims are restricted to a maximum of 7610 lbs at 120 psi.

Note - Rim listed first is the measuring rim. # = Intelligent Tire Article #. Minimum Dual Spacing calculated without chains. # - Exceeding the lawful speed limit is neither recommended nor endorsed. Overall widths will change 0.1 inch (2.5 mm) for each 1/4 inch change in rim width. 315/80R22.5 tires used on 8.25" rims are restricted to a maximum of 7160 lbs at 120 psi. Minimum dual spacing should be adjusted accordingly. Continental Tire the Americas, LLC reserves the right to change product specifications at any time without notice or obligations. Please consult rim manufacturers load and inflation limits. Never exceed rim manufacturers limits without permission of component manufacturer.

CONSTRUCTION

Features & Benefits

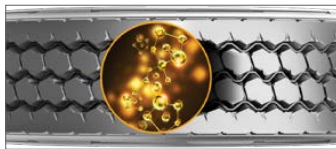

Aggressive on/off-road tread design with enhanced cap/base compounds for **improved mileage and traction**.



Built on the innovative Conti 3G Casing with **premium off-road belt package** for maximum retreadability and increased casing life.

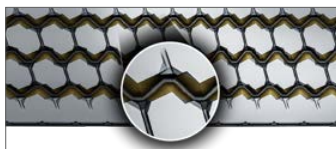

Self-cleaning tread design and groove geometry reduces stone retention for enhanced retreadability.



Maximum sidewall protection for improved resistance against curbing, cuts and abrasions.

sensor CONNECT Continental's Intelligent Tire

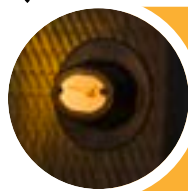

- Equipped with TPMS Sensor for accurate, real-time tire pressure and temperature readings.
- Sensor warrantied for 5 Years to minimize disruptions.
- Sensor provides true casing temperature allowing preventive actions that make your tire last longer.
- Avoids valve damage and air leaks by mounting on the inner liner.

Learn more at www.continental-truck.com. See warranty policy for details.



This product is **Mud + Snow Certified**.

Applications: Construction, coal haulers, logging and other all-position service.

3G Casing	SmartWay® Verified	Intelligent Tire	Retread Available

PRODUCT FEATURES ABOVE ONLY APPLY TO PRODUCTS IF THE MATCHING ICON IS DARKENED.

Conti HAC 3

Intelligent Construction All-Position



GOODS PEOPLE CONSTRUCTION

PRODUCT DATA

TIRE SIZE	LOAD RANGE	ARTICLE NUMBER	TREAD DEPTH (32nds)	MAX SPEED (MPH)	STATIC LOADED RADIUS		OVERALL INFLATED DIAMETER		OVERALL INFLATED WIDTH		LOADED SECTION WIDTH		APPROVED RIM(S)	MINIMUM DUAL SPACING		REVS PER UNIT		TIRE WEIGHT		MAX. LOAD @ INFLATION	
					IN	MM	IN	MM	IN	MM	IN	MM		IN	MM	MI	KM	LB	KG	LBS, PSI (KG, KPa)	LBS, PSI (KG, KPa)
385/65R22.5	L	05652000000	22	68	19.6	498	42.0	1067	14.8	376	15.9	404	11.75,12.25	N/A	N/A	493	306	171	78	9920, 130 (4500, 900)	N/A
425/65R22.5	L	05652010000	24	68	20.8	529	44.8	1138	16.6	421	17.9	454	13.00, 12.25, 14.00	N/A	N/A	462	287	190	86	11400,120 (5150, 830)	N/A
445/65R22.5	M	05652020000	23	68	20.9	531	45.2	1148	17.4	442	18.6	472	13.00,14.00	N/A	N/A	458	285	210	95	12800,130 (5800, 900)	N/A

TUBELESS TIRES ON 15 DEGREE DROP CENTER RIMS

Note - Rim listed first is the measuring rim. 0 = Intelligent Tire Article #. # - Exceeding the lawful speed limit is neither recommended nor endorsed. Overall widths will change 0.1 inch (2.5 mm) for each 1/4 inch change in rim width. Minimum dual spacing should be adjusted accordingly. Continental Tire the Americas, LLC reserves the right to change product specifications at any time without notice or obligations. Please consult rim manufacturers load and inflation limits. Never exceed rim manufacturers limits without permission of component manufacturer.

Features & Benefits

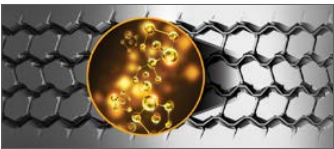

Aggressive on/off-road tread design combined with enhanced cap/base compounds for **improved mileage and traction**.



Rugged 4-belt tread package resists impacts, bruises and penetrations for improved casing durability.



Minimal stone retention due to **self-cleaning tread pattern** and groove geometry for enhanced retreadability.



Increased sidewall gauge for improved resistance against curbing, cuts and abrasions.



Continental's Intelligent Tire

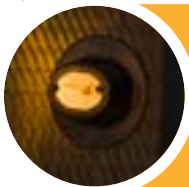

- Equipped with TPMS Sensor for accurate, real-time tire pressure and temperature readings.
- Sensor warranted for 5 Years to minimize disruptions.
- Sensor provides true casing temperature allowing preventive actions that make your tire last longer.
- Avoids valve damage and air leaks by mounting on the inner liner.

Learn more at www.continental-truck.com. See warranty policy for details.



This product is Mud + Snow Certified.

Applications: Wide base, all-position fitment for on/off-road, mixed service applications such as cement mixers.

 3G Casing	 SmartWay® Verified	 Intelligent Tire	 Retread Available
--	--	--	---

PRODUCT FEATURES ABOVE ONLY APPLY TO PRODUCTS IF THE MATCHING ICON IS DARKENED.

Conti HDC 3

Intelligent Construction Drive



 GOODS  PEOPLE  CONSTRUCTION

PRODUCT DATA



TIRE SIZE	LOAD RANGE	ARTICLE NUMBER	TREAD DEPTH (32nds)	MAX SPEED (MPH)	STATIC LOADED RADIUS		OVERALL INFLATED DIAMETER		OVERALL INFLATED WIDTH		LOADED SECTION WIDTH		APPROVED RIM(S)	MINIMUM DUAL SPACING		REVS PER UNIT		TIRE WEIGHT		MAX. LOAD @ INFLATION	
					IN	MM	IN	MM	IN	MM	IN	MM		IN	MM	MI	KM	LB	KG	LBS, PSI (KG, KPa)	LBS, PSI (KG, KPa)
11R22.5	H	05652410000	30	68	19.9	504	42.1	1069	11.7	298	12.7	322	8.25, 7.50	12.5	318	492	306	143	65	6610, 120 (3000, 830)	6005, 120 (2725, 830)
11R24.5	H	05652430000	30	68	20.7	526	44.1	1120	11.7	298	12.8	324	8.25, 7.50	12.5	318	469	292	153	69	7160, 120 (3250, 830)	6610, 120 (3000, 830)

TUBELESS TIRES ON 15 DEGREE DROP CENTER RIMS

Note - Rim listed first is the measuring rim. # = Intelligent Tire Article #. Minimum Dual Spacing calculated without chains. # - Exceeding the lawful speed limit is neither recommended nor endorsed. Overall widths will change 0.1 inch (2.5 mm) for each 1/4 inch change in rim width. Minimum dual spacing should be adjusted accordingly. Continental Tire the Americas, LLC reserves the right to change product specifications at any time without notice or obligations. Please consult rim manufacturers load and inflation limits. Never exceed rim manufacturers limits without permission of component manufacturer.

Features & Benefits

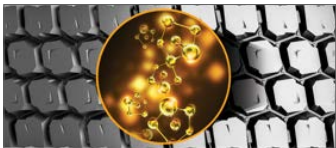

Wide, aggressive open shoulder tread design with enhanced cap/base compounds for **improved mileage and traction.**



Diamond shaped lugs and optimal void volume for excellent traction.

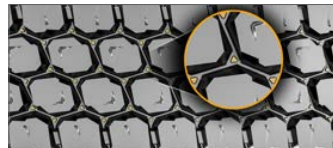

Self-cleaning tread design and miniature stone bumpers reduce stone retention for enhanced retreadability.



Maximum sidewall protection for improved resistance against curbing, cuts and abrasions.

Continental's Intelligent Tire



- Equipped with TPMS Sensor for accurate, real-time tire pressure and temperature readings.
- Sensor warranted for 5 Years to minimize disruptions.
- Sensor provides true casing temperature allowing preventive actions that make your tire last longer.
- Avoids valve damage and air leaks by mounting on the inner liner.

Learn more at www.continental-truck.com. See warranty policy for details.



This product is Mud + Snow Certified.

Applications: Construction, coal haulers, logging, waste haulers and other on/off-road service.

			
3G Casing	SmartWay® Verified	Intelligent Tire	Retread Available

PRODUCT FEATURES ABOVE ONLY APPLY TO PRODUCTS IF THE MATCHING ICON IS DARKENED.

HDC1 HT

Construction Drive for High Traction

 GOODS  PEOPLE  CONSTRUCTION

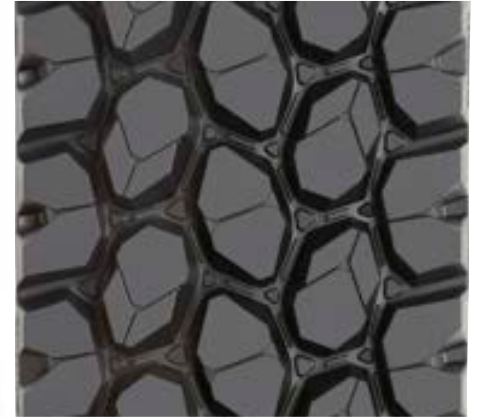

PRODUCT DATA



TIRE SIZE	LOAD RANGE	ARTICLE NUMBER	TREAD DEPTH (32nds)	MAX SPEED (MPH)	STATIC LOADED RADIUS		OVERALL INFLATED DIAMETER		OVERALL INFLATED WIDTH		LOADED SECTION WIDTH		APPROVED RIMS)	MINIMUM DUAL SPACING		REVS PER UNIT		TIRE WEIGHT		MAX. LOAD @ INFLATION	
					IN	MM	IN	MM	IN	MM	IN	MM		IN	MM	MI	KM	LB	KG	LBS, PSI (KG, KPa)	LBS, PSI (KG, KPa)
11R22.5	H	05250950000	32	68	19.9	505	42.2	1072	11.6	295	13.0	330	8.25	12.5	318	491	305	136	62	6610, 120 (3000, 830)	6005, 120 (2725, 830)
11R24.5	H	05250810000	32	68	20.7	526	44.2	1123	11.6	295	12.5	318	8.25	12.5	318	468	291	146	66	7160, 120 (3250, 830)	6610, 120 (3000, 830)

TUBELESS TIRES ON 15 DEGREE DROP CENTER RIMS

Note - Rim listed first is the measuring rim. Minimum Dual Spacing calculated without chains. # - Exceeding the lawful speed limit is neither recommended nor endorsed. Overall widths will change 0.1 inch (2.5 mm) for each 1/4 inch change in rim width. Minimum dual spacing should be adjusted accordingly. Continental Tire the Americas, LLC reserves the right to change product specifications at any time without notice or obligations. Please consult rim manufacturers load and inflation limits. Never exceed rim manufacturers limits without permission of component manufacturer.

Features & Benefits

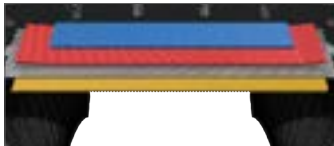

Rigid belt package with full width top belt and extra sidewall protection for increased durability.

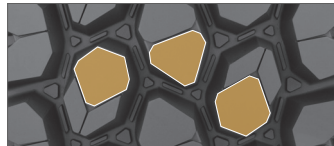

Diamond shaped tread lug design and shoulder notches are optimal for chaining.

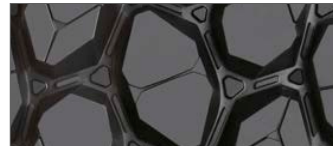

Alternating groove geometry and stone bumper system for maximum stone ejection.



Built on the innovative **Conti 3G Casing** for maximum retreadability.



This product is Mud + Snow Certified.

Applications: Severe Service On/Off Road Drive Position.

			
3G Casing	SmartWay® Verified	Intelligent Tire	Retread Available

PRODUCT FEATURES ABOVE ONLY APPLY TO PRODUCTS IF THE MATCHING ICON IS DARKENED.

HTC

Construction Trailer

 GOODS  PEOPLE  CONSTRUCTION



PRODUCT DATA



TIRE SIZE	LOAD RANGE	ARTICLE NUMBER	TREAD DEPTH (32nds)	MAX SPEED (MPH)	STATIC LOADED RADIUS		OVERALL INFLATED DIAMETER		OVERALL INFLATED WIDTH		LOADED SECTION WIDTH		APPROVED RIM(S)	MINIMUM DUAL SPACING		REVS PER UNIT		TIRE WEIGHT		MAX. LOAD @ INFLATION	
					IN	MM	IN	MM	IN	MM	IN	MM		IN	MM	IN	MM	MI	KM	LB	KG
275/70R22.5	J	0 5350480000 # 05652930000	21	62	17.6	447	38.3	974	10.8	275	11.3	287	8.25, 7.50	12.2	311	551	342	108	49	6940, 125 (3150, 860)	6395, 125 (2900, 860)

TUBELESS TIRES ON 15 DEGREE DROP CENTER RIMS

Note - Rim listed first is the measuring rim. # = Intelligent Tire Article # - Exceeding the lawful speed limit is neither recommended nor endorsed. Overall widths will change 0.1 inch (2.5 mm) for each 1/4 inch change in rim width. Minimum dual spacing should be adjusted accordingly. Continental Tire the Americas, LLC reserves the right to change product specifications at any time without notice or obligations. Please consult rim manufacturers load and inflation limits. Never exceed rim manufacturers limits without permission of component manufacturer.

Features & Benefits

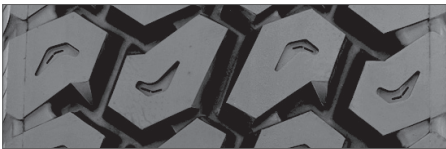

Aggressive multi-service, **all-position tread pattern** provides excellent traction in on/off road service.

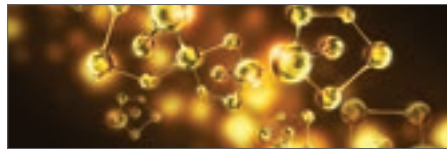

Cut and tear resistant tread compound for long tread life in on/off road conditions.



Thick undertread resists casing penetration and damage for multiple retreads.



This product is 3PMSF Certified.



This product is Mud + Snow Certified.

Applications: All-position fitment in on/off highway service.



Construction

Retread Product Overview

For Durability On & Off-Road

Legend:

SmartWay® Verified	New Tire Available



HSC 3
 



HSC - 18/32"
 



HDC 3
 



HTC1
 

Legend:



SmartWay® Verified New Tire Available

ContiTread™ HSC 3 | Construction Steer/All-Position



PRODUCT DATA		
WIDTH (MM)	ARTICLE NUMBER	TREAD DEPTH (32nds)
210	18215050000	24
220	18215060000	24
230	18215070000	24
240	18215080000	24

- Enhanced compound for improved mileage and chip and chunk resistance.
- Groove geometry reduces stone retention for enhanced retreadability.
- Rounded closed shoulder design to improve wear and optimize durability in multi-axle positions.

ContiTread™ HSC | Construction All-Position



PRODUCT DATA		
WIDTH (MM)	ARTICLE NUMBER	TREAD DEPTH (32nds)
215	18205480000	18
225	18205490000	18
235	18205500000	18

- On/Off-road compound increases resistance to cuts, chips and chunks. Also, reduces the number and depth of any cuts and tears.
- Patented innovative groove technology leads to minimum stone retention, extending casing life.

ContiTread™ HDC 3 | Construction Drive



PRODUCT DATA		
WIDTH (MM)	ARTICLE NUMBER	TREAD DEPTH (32nds)
210	18215090000	28
220	18215100000	28
230	18215110000	28
240	18215120000	28
250	18215130000	28

- Diamond shaped lugs and optimal void volume for excellent traction.
- Open shoulder tread design for use in mud, gravel and dirt.
- Enhanced compound for improved mileage and chip and chunk resistance.
- Self-cleaning tread pattern and miniature stone bumpers reduce stone retention for enhanced retreadability.

ContiTread™ HTC1 | Construction Trailer



PRODUCT DATA		
WIDTH (MM)	ARTICLE NUMBER	TREAD DEPTH (32nds)
320	18206760000	24
350	18206770000	24
380	18219490000	23

- Aggressive multi-surface, all-position tread pattern provides excellent traction.
- Outstanding self-cleaning properties ensure a long service life.



ContiPressureCheck™

On-Vehicle Tire Pressure Monitoring System



Increased Mileage



Longer Tread Life



Longer Casing Life



Reduced Roadside Breakdowns



ContiPressureCheck™ monitors a single vehicle in real-time, alerting the driver to tire pressure and temperature issues via an in-cab display. It is ideal for fleets whose trucks or buses are away from the terminal for long periods of time, and for owner-operators. Fleets benefit from extended tire and casing life, as well as increasing fuel economy and improving safety over the road.

How does it work? Tire-mounted sensors transmit tire pressure and temperature data. The data is displayed in real-time to the driver via a display screen mounted in the cab of the vehicle.

Extend the functionality of your ContiPressureCheck™ system

With Telematics Integration, display tire data remotely via any of our existing telematics partners: Zonar, PeopleNet, Geotab, and Road Ready. To learn more about our integration capabilities, visit www.continental-truck.com.





Excellent Traction // Hours of Service // Cut/Tear Resistant // Casing Durability

Off-Road

For Severe Service & Maximum Durability

Engineered for your application. Tires for Off-Road and Severe Service use are designed to support construction, mining, logging, and other applications where vehicles travel across challenging surfaces strewn with rocks, nails, and debris. Tires are optimized for durability and high removal mileage, as well as cut-and-tear resistance and traction.

IMPORTANT NOTE: Tire Products are now classified by route. Product details are subject to change, please visit our website or contact your local sales representative for the most up to date information.

Legend:

 3G Casing	 SmartWay® Verified	 Intelligent Tire	 Retread Available
--	---	---	--

PRODUCT FEATURES ABOVE ONLY APPLY TO PRODUCTS IF THE MATCHING ICON IS DARKENED.

Off-Road

Truck Tire Product Overview



HCS
   



HDO
   



Conti Terra HD3 (19.5")
   

			
3G Casing	SmartWay® Verified	Intelligent Tire	Retread Available

PRODUCT FEATURES ABOVE ONLY APPLY TO PRODUCTS IF THE MATCHING ICON IS DARKENED.

HCS

Severe Service All-Position

 GOODS  PEOPLE  CONSTRUCTION



PRODUCT DATA

TIRE SIZE	LOAD RANGE	ARTICLE NUMBER	TREAD DEPTH (32nds)	MAX SPEED (MPH)	STATIC LOADED RADIUS		OVERALL INFLATED DIAMETER		OVERALL INFLATED WIDTH		LOADED SECTION WIDTH		APPROVED RIMS	MINIMUM DUAL SPACING		REVS PER UNIT		TIRE WEIGHT		MAX. LOAD @ INFLATION	
					IN	MM	IN	MM	IN	MM	IN	MM		IN	MM	MI	KM	LB	KG	LBS, PSI (KG, KPa)	LBS, PSI (KG, KPa)
445/65R22.5	L	05160660000 #05653580000	27	68	20.9	532	45.5	1156	17.7	449	19.0	482	1300,1400	N/A	N/A	462	287	207	94	12800,130 (5800,900)	N/A
325/95R24 (NHS)	J	05160340000	40	50	22.4	568	49.3	1252	12.8	325	13.1	332	8.50,9.00	14.2	360	430	267	204	92	9370, 120 (4250, 830)	8540, 120 (3875, 830)

TUBELESS TIRES ON 15 DEGREE DROP CENTER RIMS

Note - Rim listed first is the measuring rim. # = Intelligent Tire Article #. Minimum Dual Spacing calculated without chains. # - Exceeding the lawful speed limit is neither recommended nor endorsed. NHS - Not for Highway Use Overall widths will change 0.1 inch (2.5 mm) for each 1/4 inch change in rim width. Minimum dual spacing should be adjusted accordingly. Continental Tire the Americas, LLC reserves the right to change product specifications at any time without notice or obligations. Please consult rim manufacturers load and inflation limits. Never exceed rim manufacturers limits without permission of component manufacturer.

Features & Benefits

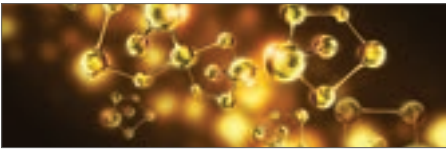

High operational safety, long lasting service and **outstanding resistance to damage through compounds** with extreme resistance to cuts and tears.



Outstanding traction, even in harshest terrain, thanks to **tread pattern structure and geometry**.



Most durable casing design for maximum service life in demanding off-road use, also involving heavy-duty vehicles.

M+S This product is Mud + Snow Certified.

Applications: All-Position service for on/off road, mining and heavy mix axles.

3G Casing	SmartWay® Verified	Intelligent Tire	Retread Available

PRODUCT FEATURES ABOVE ONLY APPLY TO PRODUCTS IF THE MATCHING ICON IS DARKENED.

HDO

Off-Road Drive

GOODS PEOPLE CONSTRUCTION



PRODUCT DATA

TIRE SIZE	LOAD RANGE	ARTICLE NUMBER	TREAD DEPTH (32nds)	MAX SPEED (MPH)	STATIC LOADED RADIUS		OVERALL INFLATED DIAMETER		OVERALL INFLATED WIDTH		LOADED SECTION WIDTH		APPROVED RIM(S)	MINIMUM DUAL SPACING		REVS PER UNIT		TIRE WEIGHT		MAX. LOAD @ INFLATION	
					IN	MM	IN	MM	IN	MM	IN	MM		IN	MM	MI	KM	LB	KG	LBS, PSI (KG, KPa)	LBS, PSI (KG, KPa)
11R22.5	H	05391190000	32	68	19.7	500	42.2	1072	11.0	280	12.0	306	8.25, 7.50	12.5	318	490	305	122	55	6610, 120 (3000, 830)	6005, 120 (2725, 830)

TUBELESS TIRES ON 15 DEGREE DROP CENTER RIMS

Note - Rim listed first is the measuring rim. Minimum Dual Spacing calculated without chains. # - Exceeding the lawful speed limit is neither recommended nor endorsed. Overall widths will change 0.1 inch (2.5 mm) for each 1/4 inch change in rim width. Minimum dual spacing should be adjusted accordingly. Continental Tire the Americas, LLC reserves the right to change product specifications at any time without notice or obligations. Please consult rim manufacturers load and inflation limits. Never exceed rim manufacturers limits without permission of component manufacturer.

Features & Benefits



Deep 32/32" tread with cut/chip resistant tread provides excellent traction in off-road conditions.

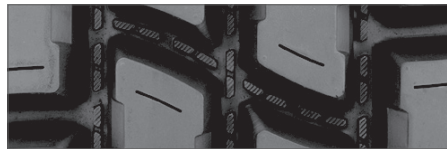

Patented innovative groove technology leads to minimum stone retention, extending casing life.



Sidewall profile with curb rib reduces damage from curbing, cuts and abrasions.

M+S This product is Mud + Snow Certified.

Applications: Logging, mining, construction and other aggressive, off-road traction needs.

			
3G Casing	SmartWay® Verified	Intelligent Tire	Retread Available

PRODUCT FEATURES ABOVE ONLY APPLY TO PRODUCTS IF THE MATCHING ICON IS DARKENED.

Conti Terra HD3

19.5" Off-Road Drive

 GOODS  PEOPLE  CONSTRUCTION



PRODUCT DATA



TIRE SIZE	LOAD RANGE	ARTICLE NUMBER	TREAD DEPTH (32nds)	MAX SPEED (MPH)	STATIC LOADED RADIUS		OVERALL INFLATED DIAMETER			OVERALL INFLATED WIDTH		LOADED SECTION WIDTH	APPROVED RIM(S)	MINIMUM DUAL SPACING		REVS PER UNIT		TIRE WEIGHT		MAX. LOAD @ INFLATION		
					IN	MM	IN	MM	IN	MM	IN			MM	IN	MM	MI	KM	LB	KG	LBS, PSI (KG, KPa)	LBS, PSI (KG, KPa)
225/70R19.5	G	05260080000	19	75	15.4	390	32.3	821	8.6	218	9.4	239	6.00, 6.75	10.0	254	640	398	67	30	3970, 110 (1800, 760)	3750, 110 (1700, 760)	
245/70R19.5	H	05260070000	19	75	15.6	395	33.3	845	9.7	245	10.3	262	7.50, 6.75	11.0	279	622	387	82	37	4940, 120 (2240, 830)	4675, 120 (2120, 830)	

TUBELESS TIRES ON 15 DEGREE DROP CENTER RIMS

Note - Rim listed first is the measuring rim. Minimum Dual Spacing calculated without chains. # - Exceeding the lawful speed limit is neither recommended nor endorsed. Overall widths will change 0.1 inch (2.5 mm) for each 1/4 inch change in rim width. Minimum dual spacing should be adjusted accordingly. Continental Tire the Americas, LLC reserves the right to change product specifications at any time without notice or obligations. Please consult rim manufacturers load and inflation limits. Never exceed rim manufacturers limits without permission of component manufacturer.

Features & Benefits



Aggressive 19/32" open shoulder tread design provides outstanding traction in off road conditions.

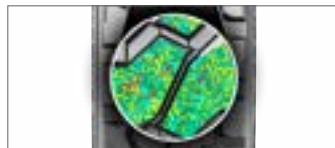

Technologically **advanced cut/tear resistant tread compound** to provide long removal miles.



Circumferential protection rib engineered to withstand severe off road terrain.



Scuff rib to protect against curbing, cuts and abrasions.



This product is Mud + Snow Certified.

Applications: Off-road severe service drive position.



ContiTread™

Off-Road Retread Product Overview



For Severe Service & Maximum Durability

Legend:

	
SmartWay® Verified	New Tire Available

ContiTread™ HCS | Severe Service All-Position





PRODUCT DATA				
WIDTH (MM)	ARTICLE NUMBER	TREAD DEPTH (32nds)		
215	18213510000	32		
225	18213520000	32		
235	18213530000	32		
245	18213540000	32		
360	18213550000	32		
380	18213560000	32		

- Cut and tear resistant tread compound for long tread life in On/Off road conditions.
- Outstanding self-cleaning properties ensure a long service life.
- Aggressive tread pattern provides excellent traction.

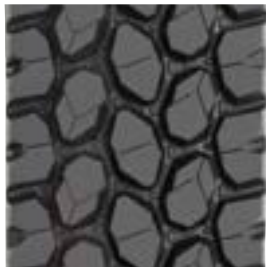
ContiTread™ HDC1 HT | Construction Drive for High Traction



PRODUCT DATA				
WIDTH (MM)	ARTICLE NUMBER	TREAD DEPTH (32nds)		
225	18211140000	32		
235	18211150000	32		
245	18211160000	32		

- Diamond shaped tread lug design and shoulder notches are optimal for chaining.
- Alternating groove geometry and stone bumper system for maximum stone ejection.
- Aggressive cut and chip resistant compounding to resist the most severe of applications.



SCAN HERE!

Digital Tire Monitoring for Truck + Trailer, Truck, or Bus.

Anytime. Anywhere.



Tire Sensor



Truck GPS
Receiver



ContiConnect LIVE
Portal/App Connection



ALWAYS
INFORMED

ContiConnect LIVE

Truck + Trailer, Truck, or Bus Solution

Key Features



Digital tire monitoring
available anytime, anywhere



Immediate actionable insights
via phone, tablet and web portal

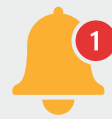

Real-time alerts for both slow
and fast tire leaks

ContiConnect LIVE Truck + Trailer, Truck, or Bus is the perfect solution to monitor your tires at all times. The web portal and mobile app give you around-the-clock access to critical tire data like GPS location, over and under inflation, rapid pressure loss, slow tire leaks, temperature, and even mileage. This gives your fleet the ultimate advantage of actionable insights towards extended tire life, reduced roadside breakdowns, improved fuel consumption and consequently Lowest Overall Driving Cost.

Scan the QR code or contact your Continental representative for more information!

Need a Representative? Call us at 1 (800) 450-3187.



SCAN HERE!

Remote Trailer & Tire Monitoring.

Even when disconnected from a power unit.



Tire Sensor

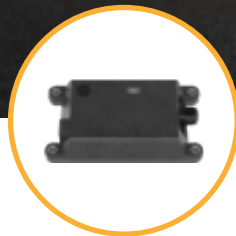

Trailer GPS Receiver



ContiConnect LIVE Portal/App Connection



ALWAYS INFORMED

ContiConnect LIVE

Standalone Trailer Solution

Key Features



Tire monitoring alerts even when not connected to a power unit



Know the status of any and all tire positions anytime, anywhere



GPS location whether the trailer is on the road or awaiting pickup

The ideal solution for any fleet frequently dropping trailers at various locations, giving you 24/7 access to valuable data like GPS location, over and under inflation, rapid pressure loss, slow tire leaks, temperature, and even mileage - **all without having to be connected to a direct power source.** Our web portal and mobile app offer added convenience with daily notifications on the status of your trailers. Get more miles out of your tires, maximize your fleet's uptime and reduce your number of emergency roadside services with the all-new **ContiConnect LIVE Trailer Solution.**

Scan the QR code or contact your Continental representative for more information!

Need a representative? Call us at 1 (800) 450-3187.



SCAN HERE!

Reduce Breakdowns. Increase Tire Life.

Digital Tire Monitoring Fit for Any Fleet.



Tire Sensor



ContiConnect Yard



ALWAYS INFORMED

ContiConnect Yard

Home Fleet Solution

Key Features



Real time tire alerts when vehicle is within range of the ContiConnect™ Yard



Digital tire monitoring for the entire fleet with just one device

ContiConnect Yard - the digital tire monitoring service designed to help centrally located fleets monitor their tires at regular intervals. The Yard reader device can be mounted stationary or mobile on a service truck or van, providing flexibility for many applications. Once active, the data collected from your tire sensors offers actionable insights to reduce tire failures, improve safety performance on the road and extend life of tires, resulting in significant savings for any fleet that regularly returns to dedicated checkpoints.





Scan the QR code or contact your Continental representative for more information!

Need a Representative? Call us at 1 (800) 450-3187.

2024

Digital Solutions Offerings

Below is a basic guide on the most up-to-date Digital Solutions offered from Continental.

					
	ContiPressure Check (CPC)	Yard Reader	CoCo™ LIVE Truck & Trailer	CoCo™ LIVE w/ Zonar	CoCo™ LIVE Trailer Solution
Driver Alerts	✓	✗	✓	✓	✗
ContiConnect™ Access	✗	✓	✓	✓	✓
Continuous Monitoring	✓	✗	✓	✓	✓
Automatic Trailer Learning	✓	✗	✓	✓	N/A
GPS	✗	✗	✓	✓	✓
Text & Email Alerts	✗	✓	✓	✓	✓
Continental Hardware Only	✓	✓	✓	✗	✓
Up to 30 days of monitoring when not connected to power	✗	✗	✗	✗	✓
TARGET USE	Fleets that may only want driver alerts. Small fleets, owner/operators.	Fleets that return to central location frequently. Domiciled/local fleets.	Fleets that require continuous monitoring or do not return to central location. Long haul, regional, etc.	Current Zonar customers that want to add TPMS.	Trailer leasing companies, fleets that need to monitor untethered trailers.

✓ Standard

✓ Optional

✗ Not Available

N/A Not Applicable

CoCo™ ContiConnect™

TABLES/CHARTS & Tire Information

Medium Truck Load/ Inflation Tables

Safety Warning

Serious Injury May Result From:

- Explosion of tire/rim assembly due to improper mounting. Use safety cage and clip-on extension air hose. Only specially trained persons should mount tires.
- Tire failure due to misapplication/improper inflation/overloading.

Follow tire manufacturer's instructions.

Check inflation pressure frequently with calibrated gauge.

Truck and Bus Tires

Normal and Wide-Base Sizes on 5 Degree or Flat-Based Rims - Radial Ply

Tire Loads Limits at Various Cold Inflation Pressures

24"		kPa	480	520	550	590	620	660	690	720	760	790	830	
		psi	70	75	80	85	90	95	100	105	110	115	120	
325/95R24	*	dual	kg	2780	2860	3020	3140	3250	3350	3450	3550	3650	3760	3875 (J)
			lbs	6120	6390	6650	6910	7160	7390	7610	7830	8050	8300	8540 (J)
	single	kg	2870	3020	3170	3300	3440	3650	3770	3890	4000	4130	4250 (J)	
		lbs	6330	6660	6980	7280	7580	8050	8310	8570	8820	9100	9370 (J)	

Conventional Sizes on 15 Degree Drop-Center Rims - Radial Ply

22.5"		kPa	480	520	550	590	620	660	690	720	760	790	825/830***	
		psi	70	75	80	85	90	95	100	105	110	115	120	
10R22.5	*	dual	kg	1750	1830	1910	2000	2080	2160	2240	2300	2360	2430 (G)	--
			lbs	3860	4045	4230	4410	4585	4760	4940	5075	5210	5355 (G)	--
	single	kg	1850	1940	2030	2120	2200	2280	2360	2430	2500	2575 (G)	--	
		lbs	4080	4280	4480	4675	4850	5025	5205	5360	5515	5675 (G)	--	
11R22.5	*	dual	kg	1990	2080	2160	2250	2360	2460	2560	2650 (G)	2680	2710	2725 (H)
			lbs	4380	4580	4760	4950	5205	5415	5625	5840 (G)	5895	5950	6005 (H)
	single	kg	2050	2160	2260	2370	2500	2600	2700	2800 (G)	2870	2940	3000 (H)	
		lbs	4530	4770	4990	5220	5510	5730	5950	6175 (G)	6320	6465	6610 (H)	
12R22.5	*	dual	kg	2170	2260	2350	2440	2575	2630	2680	2725 (G)	2840	2960	3075 (H)
			lbs	4780	4990	5190	5390	5675	5785	5895	6005 (G)	6265	6525	6780 (H)
	single	kg	2240	2360	2470	2580	2725	2820	2910	3000 (G)	3120	3240	3350 (H)	
		lbs	4940	5200	5450	5690	6005	6205	6405	6610 (G)	6870	7130	7390 (H)	

24.5"		kPa	480	520	550	590	620	660	690	720	760	790	830	
		psi	70	75	80	85	90	95	100	105	110	115	120	
11R24.5	*	dual	kg	2110	2210	2300	2390	2500	2580	2660	2725 (G)	2820	2910	3000 (H)
			lbs	4660	4870	5070	5260	5510	5675	5840	6005 (G)	6205	6405	6610 (H)
	single	kg	2190	2300	2410	2520	2650	2770	2890	3000 (G)	3080	3160	3250 (H)	
		lbs	4820	5070	5310	5550	5840	6095	6350	6610 (G)	6790	6970	7160 (H)	
12R24.5	*	dual	kg	2300	2400	2500	2600	2650	2770	2890	3000 (G)	3080	3160	3250 (H)
			lbs	5080	5300	5520	5730	5840	6095	6350	6610 (G)	6790	6970	7160 (H)
	single	kg	2380	2500	2630	2740	2900	3020	3140	3250 (G)	3350	3450	3550 (H)	
		lbs	5240	5520	5790	6040	6395	6650	6910	7160 (G)	7380	7600	7830 (H)	

* Based on TRA | ** Based On ETRTO

*** Tire & Rim Association has adopted an official equivalency of kPa to psi values. 825 replaces the previous 830.

NOTE: Letters in parentheses denote load range for which boldface loads are maximum.

CAUTION: Always use approved tire and rim combinations for diameters and contours.

NOTE: All values are for 65 mph unless otherwise noted, for tire load and inflation at various speeds, see next pages.

Truck and Bus Tires

Metric and Wide-Base Sizes on 15 Degree Drop-Center Rims - Radial Ply

Tire Loads Limits at Various Cold Inflation Pressures

16"			kPa	240	280	310	340	380	410	450	480	520	550	650		
			psi	35	40	45	50	55	60	65	70	75	80	95		
LT225/75R16	**	Dual	kg	635	675	725	800 (C)	845	885	975 (D)	1000	1040	1120 (E)	1250 (F)		
			lbs	1365	1500	1630	1765 (C)	1875	1995	2150 (D)	2220	2330	2470 (E)	2755 (F)		
		Single	kg	680	745	795	880 (C)	930	970	1060 (D)	1100	1140	1215 (E)	1360 (F)		
			lbs	1500	1650	1790	1940 (C)	2060	2190	2335 (D)	2440	2560	2680 (E)	3000 (F)		
LT235/85R16	**	Dual	kg	720	770	835	910 (C)	960	1025	1080 (D)	1140	1200	1260 (E)	1400 (F)		
			lbs	1545	1700	1845	2006 (C)	2125	2260	2381 (D)	2515	2645	2778 (E)	3085 (F)		
		Single	kg	770	845	920	1000 (C)	1055	1125	1190 (D)	1250	1315	1380 (E)	1550 (F)		
			lbs	1700	1870	2030	2205 (C)	2335	2485	2623 (D)	2765	2905	3042 (E)	3415 (F)		
LT245/75R16	**	Dual	kg	720	770	835	910 (C)	960	1020	1080 (D)	1140	1195	1260 (E)	1400 (F)		
			lbs	1545	1700	1845	2006 (C)	2125	2255	2381 (D)	2515	2640	2778 (E)	3085 (F)		
		Single	kg	770	845	920	1000 (C)	1055	1125	1190 (D)	1250	1315	1380 (E)	1550 (F)		
			lbs	1700	1870	2030	2205 (C)	2335	2480	2623 (D)	2765	2900	3042 (E)	3415 (F)		
17.5"			kPa	480	520	550	590	620	660	690	720	760	790	830	860	
			psi	70	75	80	85	90	95	100	105	110	115	120	125	
215/75R17.5	**	Dual	kg	--	--	1450	1520	1590	1650	1720	1790	1860	1925	1990	2060 (J)	
			lbs	--	--	3195	3500	3500	3645	3795	3945	4095	4245	4390	4545 (J)	
		Single	kg	--	--	1530	1610	1680	1750	1820	1900	1960	2040	2110	2180 (J)	
			lbs	--	--	3375	3540	3695	3860	4010	4180	4330	4495	4650	4805 (J)	
235/75R17.5	**	Dual	kg	--	--	--	--	--	2020	2140	2200	2325	2380	2440	2575 (J)	
			lbs	--	--	--	--	--	4450	4720	4855	5120	5250	5380	5675 (J)	
		Single	kg	--	--	--	--	--	2080	2205	2270	2395	2455	2515	2725 (J)	
			lbs	--	--	--	--	--	4580	4860	5000	5275	5410	5545	6005 (J)	
245/70R17.5	**	Dual	kg	--	--	--	--	--	2020	2140	2200	2325	2380	2440	2575 (J)	
			lbs	--	--	--	--	--	4450	4720	4855	5120	5250	5380	5675 (J)	
		Single	kg	--	--	--	--	--	2080	2205	2270	2395	2455	2515	2725 (J)	
			lbs	--	--	--	--	--	4580	4860	5000	5275	5410	5545	6005 (J)	
19.5"			kPa	480	520	550	590	620	660	690	720	760	790	830	860	900
			psi	70	75	80	85	90	95	100	105	110	115	120	125	130
225/70R19.5	*	Dual	kg	1230	1300	1360	1410	1470	1550	1580	1640	1700 (G)	1750	1800 (H)	1850	1900 (J)
			lbs	2720	2860	3000	3115	3245	3415	3490	3615	3750 (G)	3855	3970 (H)	4085	4190 (J)
		Single	kg	1310	1380	1450	1500	1570	1650	1690	1740	1800 (G)	1860	1900 (H)	1970	2000 (J)
			lbs	2895	3040	3195	3315	3450	3640	3715	3845	3970 (G)	4100	4190 (H)	4245	4410 (J)
245/70R19.5	*	Dual	kg	--	--	1550	1590	1660	1750	1790	1850	1950 (G)	--	--	--	
			lbs	--	--	3415	3515	3655	3860	3940	4075	4410 (G)	--	--	--	
		Single	kg	--	--	1650	1700	1770	1850	1900	1970	2060 (G)	--	--	--	
			lbs	--	--	3640	3740	3890	4080	4190	4335	4540 (G)	--	--	--	
245/70R19.5 (LRH Only)	*	Dual	kg	--	--	1550	1590	1660	1750	1790	1850	1950	1970	2060 (H)	--	
			lbs	--	--	3415	3515	3655	3860	3940	4075	4300	4345	4540 (H)	--	
		Single	kg	--	--	1650	1700	1770	1850	1900	1970	2060	2095	2180 (H)	--	
			lbs	--	--	3640	3740	3890	4080	4190	4335	4540	4620	4805 (H)	--	
265/70R19.5 @81 mph	**	Dual	kg	1560	1640	1700	1780	1860	1950	2000	2000	2120	2360 (H)	--	--	
			lbs	3430	3600	3750	3930	4095	4300	4405	4415	4475	5205 (H)	--	--	
		Single	kg	1660	1740	1800	1900	1970	2060	2130	2200	2300	2500 (H)	--	--	
			lbs	3650	3830	3970	4180	4355	4540	4685	4850	5070	5510 (H)	--	--	
285/70R19.5 LRH @81 mph	**	Dual	kg	--	1870	1970	2065	2160	2260	2355	2450	2540	2630	2725 (H)	--	
			lbs	--	4125	4340	4555	4770	4980	5190	5395	5600	5805	6005 (H)	--	
		Single	kg	--	1990	2100	2200	2305	2405	2505	2605	2705	2805	2900 (H)	--	
			lbs	--	4390	4625	4855	5080	5305	5525	5745	5965	6180	6395 (H)	--	
285/70R19.5 LRJ @ 68 mph	**	Dual	kg	--	--	--	2240	2345	2450	2550	2650	2750	2850	2950	3050	3150 (J)
			lbs	--	--	--	4940	5170	5400	5625	5850	6070	6290	6510	6730	6940 (J)
		Single	kg	--	--	--	2385	2495	2610	2715	2825	2930	3040	3145	3250	3350 (J)
			lbs	--	--	--	5260	5505	5750	5990	6230	6465	6700	6930	7160	7390 (J)
305/70R19.5	*	Dual	kg	--	--	2060	2120	2200	2300	2370	2450	2575	2620	2725	2900 (J)	
			lbs	--	--	4540	4670	4860	5070	5230	5410	5675	5770	6005	6395 (J)	
		Single	kg	--	--	2240	2330	2420	2500	2610	2700	2800	2870	3000	3150 (J)	
			lbs	--	--	4940	5130	5340	5510	5745	5945	6175	6340	6610	6940 (J)	

22.5"		kPa		480	520	550	590	620	660	690	720	760	790	825/830***	860	900
		psi		70	75	80	85	90	95	100	105	110	115	120	125	130
255/70R22.5	*	Dual	kg	--	--	1800	1860	1940	2000	2020	2090	2120	2230	2300 (H)	--	--
			lbs	--	--	3970	4110	4275	4410	4455	4610	4675	4915	5070 (H)	--	--
		Single	kg	--	--	1900	1980	2060	2120	2220	2300	2360	2450	2500 (H)	--	--
			lbs	--	--	4190	4370	4550	4675	4895	5065	5205	5400	5510 (H)	--	--
275/70R22.5	**	Dual	kg	--	--	--	2070	2155	2265	2345	2424	2535	2615	2720	2795	2900 (J)
			lbs	--	--	--	4565	4750	4995	5170	5345	5590	5765	5995	6160	6395 (J)
		Single	kg	--	--	--	2250	2340	2460	2550	2635	2750	2840	2955	3040	3150 (J)
			lbs	--	--	--	4960	5160	5420	5620	5810	6060	6260	6510	6700	6940 (J)
275/80R22.5	**	Dual	kg	1860	1950	2060	2130	2220	2300	2390	2470	2575 (G)	2630	2800 (H)	--	--
			lbs	4095	4300	4540	4690	4885	5070	5260	5440	5675 (G)	5795	6175 (H)	--	--
		Single	kg	2040	2140	2240	2340	2440	2500	2620	2710	2800 (G)	2890	3150 (H)	--	--
			lbs	4500	4725	4940	5155	5370	5510	5780	5980	6175 (G)	6370	6940 (H)	--	--
295/60R22.5 9.00" wheel @ 65mph	**	Dual	kg	--	--	--	2187	2290	2392	2492	2592	2787	2885	2970	3075 (J)	
			lbs	--	--	--	4825	5050	5275	5495	5715	5930	6145	6360	6570	6780 (J)
		Single	kg	--	--	--	2385	2495	2610	2715	2825	2930	3040	3145	3230	3350 (J)
			lbs	--	--	--	5260	5505	5750	5990	6230	6465	6700	6930	7160	7390 (J)
295/60R22.5 9.00" wheel @ 75mph	**	Dual	kg	--	--	--	2187	2290	2392	2492	2592	2787	2885	2970	2970 (J)	
			lbs	--	--	--	4825	5050	5275	5495	5715	5930	6145	6360	6570	6570 (J)
		Single	kg	--	--	--	2385	2495	2610	2715	2825	2930	3040	3145	3145	3230 (J)
			lbs	--	--	--	5260	5505	5750	5990	6230	6465	6700	6930	7160	7160 (J)
295/75R22.5	*	Dual	kg	1860	1950	2060	2130	2220	2300	2390	2470	2575 (G)	2630	2725 (H)	--	--
			lbs	4095	4300	4540	4690	4885	5070	5260	5440	5675 (G)	5795	6005 (H)	--	--
		Single	kg	2040	2140	2240	2340	2440	2500	2620	2710	2800 (G)	2890	3000 (H)	--	--
			lbs	4500	4725	4940	5155	5370	5510	5780	5980	6175 (G)	6370	6610 (H)	--	--
295/80R22.5	**	Dual	kg	2050	2160	2260	2370	2500	2600	2700	2800	2910	3030	3150 (H)	--	--
			lbs	4530	4770	4990	5220	5510	5730	5950	6175	6415	6670	6945 (H)	--	--
		Single	kg	2380	2500	2630	2740	2900	3020	3140	3250	3350	3450	3550 (H)	--	--
			lbs	5240	5520	5790	6040	6395	6650	6910	7160	7380	7600	7830 (H)	--	--
305/70R22.5	**	Dual	kg	1915	2020	2130	2235	2340	2445	2545	2645	2745	2845	2945	3150 (L)	--
			lbs	4220	4450	4700	4930	5160	5390	5610	5830	6050	6270	6490	6940 (L)	--
		Single	kg	2155	2280	2400	2520	2635	2755	2870	2985	3095	3210	3320	3430	3550 (L)
			lbs	4750	5030	5290	5560	5810	6070	6330	6580	6820	7080	7320	7560	7830 (L)
315/80R22.5	*	Dual	kg	--	--	2575	2650	2750	2900	2970	3070	3150	3270	3450	3600	3750 (L)
			lbs	--	--	5675	5840	6070	6395	6545	6770	6940	7210	7610	7940	8270 (L)
		Single	kg	--	--	2800	2910	3030	3150	3260	3370	3450	3590	3750	3960	4125 (L)
			lbs	--	--	6175	6415	6670	6940	7190	7440	7610	7920	8270	8600	9090 (L)
315/80R22.5** speed restricted LRL		Dual	kg	--	--	2800	2910	3030	3150	3260	3370	3450	3590	3750	3940	4125 (L)
			lbs	--	--	6175	6415	6670	6940	7190	7440	7610	7920	8270	8680	9090 (L)
		Single	kg	--	--	3050	3170	3300	3430	3550	3670	3760	3910	4125	4330	4540 (L)
			lbs	--	--	6725	6990	7275	7560	7825	8090	8290	8620	9090	9545	10000 (L)
385/65R22.5	**	Dual	kg	--	--	--	--	--	--	--	--	--	--	--	--	--
			lbs	--	--	--	--	--	--	--	--	--	--	--	--	--
		Single	kg	2880	3060	3150	3350	3470	3650	3740	3850	4000	4100	4250	4360	4500 (L)
			lbs	6380	6720	6940	7350	7650	8050	8230	8510	8820	9050	9370	9610	9920 (L)
425/65R22.5	**	Dual	kg	--	--	--	--	--	--	--	--	--	--	--	--	--
			lbs	--	--	--	--	--	--	--	--	--	--	--	--	--
		Single	kg	3430	3640	3750	3980	4130	4250	4440	4580	4750	4880	5150 (L)	--	--
			lbs	7590	7990	8270	8740	9100	9370	9790	10100	10500	10700	11400 (L)	--	--
445/50R22.5	*	Dual	kg	--	--	--	--	--	--	--	--	--	--	--	--	--
			lbs	--	--	--	--	--	--	--	--	--	--	--	--	--
		Single	kg	--	3150	3320	3480	3640	3810	3970	4120	4250	4430	4625 (L)	--	--
			lbs	--	6940	7310	7680	8030	8390	8740	9090	9370	9780	10200 (L)	--	--
445/65R22.5	*	Dual	kg	--	--	--	--	--	--	--	--	--	--	--	--	--
			lbs	--	--	--	--	--	--	--	--	--	--	--	--	--
		Single	kg	3720	3950	4125	4320	4470	4625	4820	4960	5150	5290	5600 (L)	--	5800 (M)
			lbs	8230	8660	9090	9480	9870	10200	10600	11000	11400	11700	12300 (L)	--	12800 (M)

24.5"		kPa		480	520	550	590	620	660	690	720	760	790	830
		psi		70	75	80	85	90	95	100	105	110	115	120
285/75R24.5	*	Dual	kg	1870	1970	2060	2150	2240	2360	2410	2490	2575 (G)	2660	2800 (H)
			lbs	4135	4340	4540	4740	4930	5205	5310	5495	5675 (G)	5860	6175 (H)
		Single	kg	2060	2160	2240	2360	2460	2575	2650	2740	2800 (G)	2920	3075 (H)
			lbs	4545	4770	4940	5210	5420	5675	5835	6040	6175 (G)	6440	6780 (H)

* Based on TRA | ** Based On ETRTO

*** Tire & Rim Association has adopted an official equivalency of kPa to psi values. 825 replaces the previous 830.

NOTE: Letters in parentheses denote load range for which boldface loads are maximum.

Load Limits At Various Speeds

For Radial Ply Truck Tires Used On Improved Surfaces

(These Tables apply to tires only. Consult rim/wheel manufacturer for rim/wheel load and inflation capacities.)

Tire And Rim Association Standard

FOR METRIC AND WIDE BASE TIRES

The service load and minimum (cold) inflation must comply with the following limitations unless a speed restriction is indicated on the tire or the manufacturer rates the tire at 75 mph or above.

SPEED RANGE (MPH)	RADIAL PLY TIRES	
	INFL. PRESSURE CHANGE	% LOAD CHANGE
71 thru 75	+5 psi	-12%
66 thru 70	+5 psi	-4%
51 thru 65	No Increase	None
41 thru 50	No Increase	+7%
31 thru 40	No Increase	+9%
21 thru 30	+10 psi	+12%
11 thru 20	+15 psi	+17%
6 thru 10	+20 psi	+25%
2.6 thru 5	+20 psi	+45%
Creep thru 2.5	+20 psi	+55%
Creep (2)	+30 psi	+75%
Stationary	+30 psi	+105%

FOR CONVENTIONAL TIRES

The service load and minimum (cold) inflation must comply with the following limitations unless a speed restriction is indicated on the tire or the manufacturer rates the tire at 75 mph or above.

SPEED RANGE (MPH)	RADIAL PLY TIRES	
	INFL. PRESSURE CHANGE	% LOAD CHANGE
71 thru 75	+5 psi	-12%
66 thru 70	+5 psi	-4%
51 thru 65	No Increase	None
41 thru 50	No Increase	+9%
31 thru 40	No Increase	+16%
21 thru 30	+10 psi	+24%
11 thru 20	+15 psi	+32%
6 thru 10 (1)	+30 psi	+60%
2.6 thru 5 (1)	+30 psi	+85%
Creep thru 2.5 (1)	+30 psi	+115%
Creep (1) (2)	+40 psi	+140%
Stationary (1)	+40 psi	+185%

NOTES

1. Apply these increases to Dual Loads and Inflation Pressures.
2. Creep - Motion for not over 200 feet in a 30-minutes period.

Note 1: The inflation pressures shown in the minimum cold pressures for the various loads listed.
Higher pressures should be used as follows:

- A. When required by the above speed/load table.
- B. When higher pressures are desirable to obtain improved operating performance. For speeds above 20 mph, the combined increases of A and B should not exceed 20 psi above the inflation specified for the maximum load of the tire.

Note 2: Load limits at various speed for:
Tires used in highway service at Restricted Speed.
Mining and Logging Tires used in Intermittent Highway Service.

THE MAXIMUM LOAD AND INFLATION CAPACITY OF THE RIM MUST NOT BE EXCEEDED.

Load Limits At Various Speeds

Tires Rated At 75 MPH And Radial Ply Truck Tires Used On Improved Surfaces

(These tables apply to tires only. Consult rim/wheel manufacturer for rim/wheel load and inflation capacities.)

Tire And Rim Association Standard

FOR METRIC AND WIDE BASE TIRES		
SPEED RANGE (MPH)	RADIAL PLY TIRES	
	INFL. PRESSURE CHANGE	% LOAD CHANGE
71 thru 75	No Increase	None
66 thru 70	No Increase	None
51 thru 65	No Increase	None
41 thru 50	No Increase	+7%
31 thru 40	No Increase	+9%
21 thru 30	+10 psi	+12%
11 thru 20	+15 psi	+17%
6 thru 10	+20 psi	+25%
2.6 thru 5	+20 psi	+45%
Creep thru 2.5	+20 psi	+55%
Creep (2)	+30 psi	+75%
Stationary	+30 psi	+105%

FOR CONVENTIONAL TIRES		
SPEED RANGE (MPH)	RADIAL PLY TIRES	
	INFL. PRESSURE CHANGE	% LOAD CHANGE
71 thru 75	No Increase	None
66 thru 70	No Increase	None
51 thru 65	No Increase	None
41 thru 50	No Increase	+9%
31 thru 40	No Increase	+16%
21 thru 30	+10 psi	+24%
11 thru 20	+15 psi	+32%
6 thru 10 (1)	+30 psi	+60%
2.6 thru 5 (1)	+30 psi	+85%
Creep thru 2.5 (1)	+30 psi	+115%
Creep (1) (2)	+40 psi	+140%
Stationary (1)	+40 psi	+185%

NOTES

1. Apply these increases to Dual Loads and Inflation Pressures.
2. Creep - Motion for not over 200 feet in a 30-minutes period.

Note 1: The inflation pressures shown in the minimum cold pressures for the various loads listed.

Higher pressures should be used as follows:

- A. When required by the above speed/load table.
- B. When higher pressures are desirable to obtain improved operating performance. For speeds above 20 mph, the combined increases of A and B should not exceed 20 psi above the inflation specified for the maximum load of the tire.

THE MAXIMUM LOAD AND INFLATION CAPACITY OF THE RIM MUST NOT BE EXCEEDED.

Reading Tire Information

Tire Sidewall

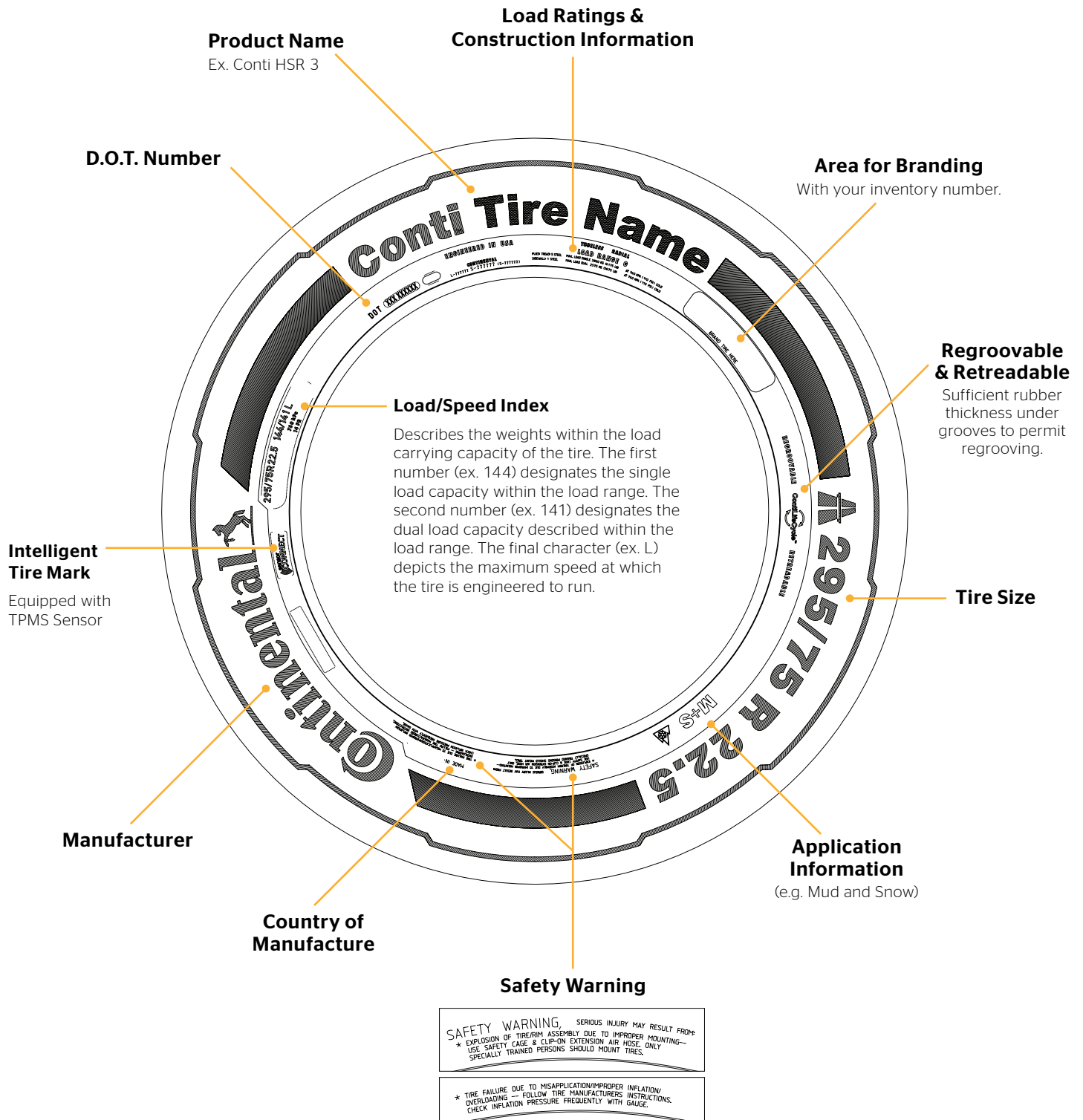

Reading Tire Information

DOT Code

Manufacturing Codes

Characters 1 & 2 = Manufacturer and Plant

Characters 3 & 4 = Tire Size Code

Characters 5/6/7 = Tire Type or Model

New Tire - D.O.T. Number



Department of Transportation

ALL TIRES USED IN U.S.A. MUST DISPLAY A D.O.T. NUMBER.

Date of Manufacturing

Characters 1 & 2 = Week of Manufacture (01 - 53)

Characters 3 & 4 = Year of Manufacture (Last 2 Digits)

Retreaded Tire - D.O.T. Number

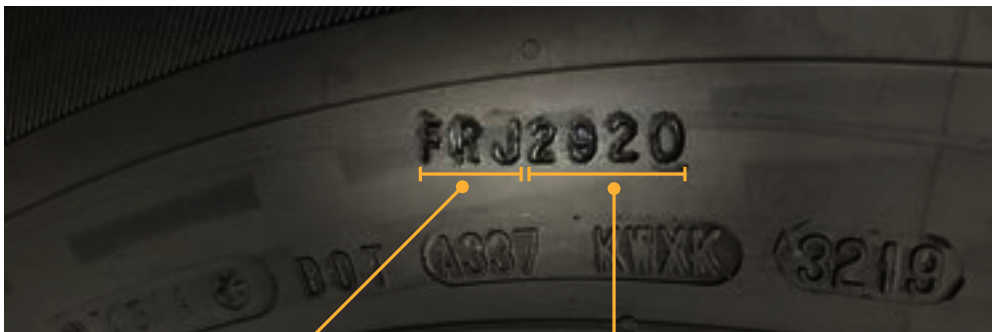

Manufacturing Retread Facility

Characters 1 - 3 = Retread Facility

Date of Manufacturing

Characters 4 & 5 = Week of Manufacture (01 - 53)

Characters 6 & 7 = Year of Manufacture (Last 2 Digits)

Reading Tire Information

New Generation Product Naming

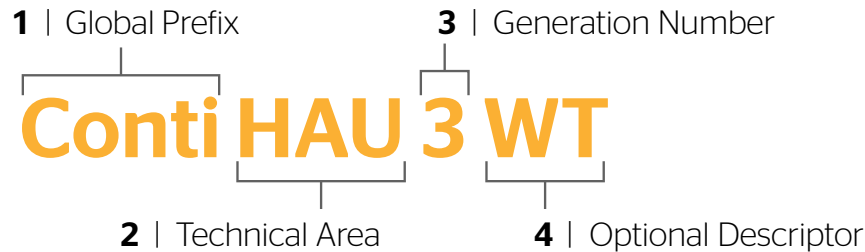

Step 1 Global Prefix

Moving forward, every new tire will begin with Conti (or ContiTread™ for retread), regardless of segment, region, or application. This universal prefix will help unify our diverse product line.

Step 2 Technical Area

This area provides essential information to help ensure the right tire goes on the right vehicle.

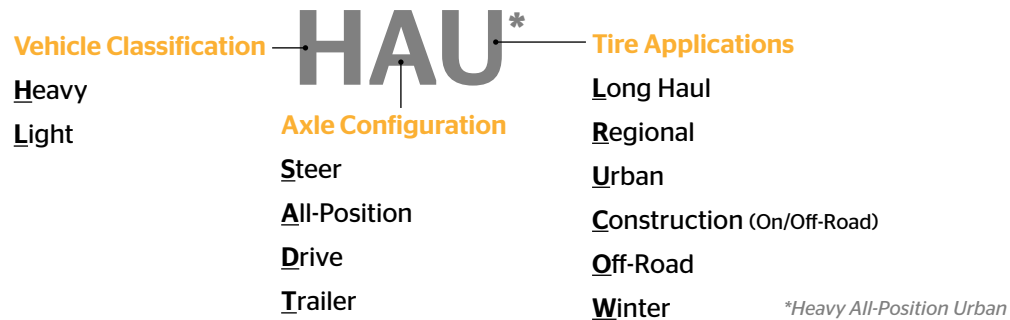

Step 3 Generation Number (1st, 2nd, 3rd, 5th, etc.)

Step 4 Optional Descriptor

Although it may be left blank, this space covers additional information about a tire's specialized characteristics to help our customers find the optimal tire.

EP Eco Plus | **DL** Deep Lug | **WT** Waste Transport | **& more...**

PLEASE NOTE: If these two characters are included, they are part of the tire name and essential to its identification. For example, a **Conti HSL 3** and a **Conti HSL 3 EP** could both exist, and would be two entirely different tires with different tread patterns, article numbers, and benefits.



Example 1: Conti HSL 3

Heavy Vehicle / Steer Axle / Long Haul Application (3rd Generation)



Example 2: Conti HSR 3

Heavy Vehicle / Steer Axle / Regional Application (3rd Generation)

Definitions

New Tire Dimensions

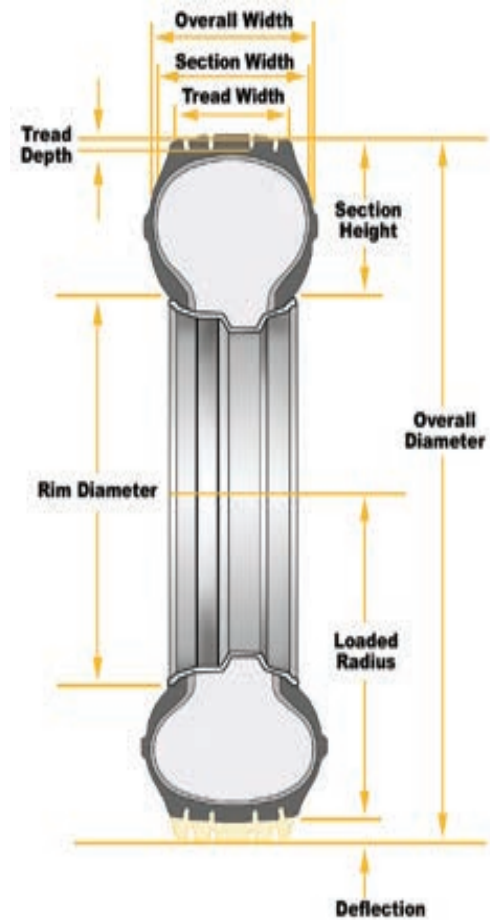
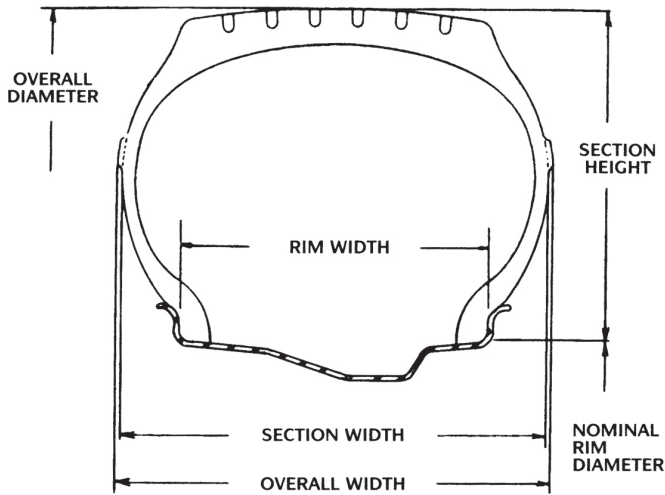

Aspect Ratio	Section Height Section Width
Rim Width	Linear distance between the flanges of the rim.
Static Loaded Radius	Distance from wheel axle centerline to supporting tread surface at a given load and pressure in a static condition.
Tire (Overall) Width	The width of a new tire, including 24-hour inflation growth, and including protective side ribs, bars and decorations.
Section Height	Half the difference between the overall diameter and the nominal rim diameter.
Overall Diameter	The diameter of an inflated tire at the outermost surface of the tread, including 24-hour inflation growth.
Revolutions Per Mile	Measured number of revolutions for a tire traveling one mile. This can vary with speed, load, and inflation.
Tread Width	Distance across tread from shoulder to shoulder.
Width Loaded	Tire width (overall) under rated load conditions.
Minimum Dual Spacing	Minimum dual tire centerline to centerline measurement.
Section Width	Linear distance between outside of sidewalls of inflated tire (exclusive of markings, etc.).

Low Aspect Ratio Tires

24.5 Inch Highway Size

(USING TYPICAL DESIGN DIMENSIONS)

Match Tire For Speed And Axle Weights

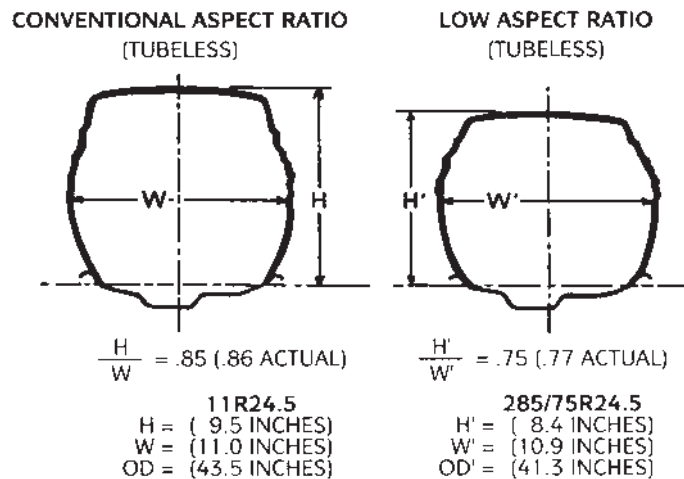

In a tire selection process, it is mandatory that consideration be given to selecting a tire size and load range which at least equals the maximum load requirements by axle position (steer, drive or trail). All highway truck tires have load limits established for tires used in normal highway service. Therefore, when selecting a tire for service, both the carrying capacity and speed implications must be considered.

TIRE LOAD LIMITS AT VARIOUS COLD INFLATION PRESSURES										
THE PRESSURE IS MINIMUM FOR LOAD										
MAXIMUM SPEED OF 65 (MPH)						Example for LRG				
SIZE			70 (480)	75 (520)	80 (550)	85 (590)	90 (620)	95 (660)	100 (690)	105 (720)
11R22.5	Dual	kg	1990	2080	2160	2250	2360	2460	2560	2650 (G)
		lbs	4380	4580	4760	4950	5205	5415	5625	5840 (G)
	Single	kg	2050	2160	2260	2370	2500	2600	2700	2800 (G)
		lbs	4530	4770	4990	5220	5510	5730	5950	6175 (G)
11R24.5	Dual	kg	2110	2210	2300	2390	2500	2580	2660	2725 (G)
		lbs	4660	4870	5070	5260	5510	5675	5840	6005 (G)
	Single	kg	2190	2300	2410	2520	2650	2770	2890	3000 (G)
		lbs	4820	5070	5310	5550	5840	6095	6350	6610 (G)

For example, when selecting tires for a tractor and trailer combination with a gross combination weight (GCW) of 80,000 lbs. and an axle weight distribution of 12,000 lbs. on the steer, 34,000 lbs. on the tandem drive and 34,000 lbs. on the tandem trailer axles, the most common conventional tire sizes used are 11R22.5 Load Range G and 11R24.5 Load Range G. The load and inflation schedule according to the Tire and Rim Association tables for these sizes is shown above.

Service Descriptions

Continental Tire the Americas, LLC provides a service description onto the sidewall of all premium products.

This service description, which consists of one or more load indices and speed symbols, is located close to the tire size designation on the sidewall of the tire.

The load index relates to the maximum load carrying capacities allowed at the speed indicated by the speed symbol.

The speed symbol relates to the maximum speed allowed for the load carrying capacities associated with the load index.

The following is an example of a load index / speed symbol associated with a medium radial truck tire:

144/141



Load Indices
(Single/Dual)

L



Speed Symbol

The attached chart shows the comparison of load index to load and speed symbol to maximum speed for radial truck tire products.

Consult your local Continental Tire representative for confirmation of the suitability of the tire/wheel assembly for the intended service.

Truck-Bus Metric Tires

International Load Index Numbers

LOAD INDEX	Kg	Lbs.
119	1360	3000
120	1400	3085
121	1450	3195
122	1500	3305
123	1550	3415
124	1600	3525
125	1650	3640
126	1700	3750
127	1750	3860
128	1800	3970
129	1850	4080
130	1900	4190
131	1950	4300
132	2000	4410
133	2060	4540
134	2120	4675
135	2180	4805
136	2240	4940
137	2300	5070
138	2360	5205
139	2430	5355
140	2500	5510
141	2575	5675
142	2650	5840
143	2725	6005
144	2800	6175

LOAD INDEX	Kg	Lbs.
145	2900	6395
146	3000	6610
147	3075	6780
148	3150	6940
149	3250	7160
150	3350	7390
151	3450	7610
152	3550	7830
153	2650	8050
154	3750	8270
155	3875	8540
156	4000	8820
157	4125	9090
158	4250	9370
159	4375	9650
160	4500	9920
161	4625	10200
162	4750	10500
163	4875	10700
164	5000	11000
165	5150	11400
166	5300	11700
167	5450	12000
168	5600	12300
169	5800	12800
170	6000	13200

SPEED SYMBOL	SPEED (kmh)	SPEED (mph)
F	80	50
G	90	56
J	100	62
K	110	68
L	120	75
M	130	81
N	140	87
P	150	93
Q	160	99
R	170	106
S	180	112
T	190	118

LOAD RANGE	PLY RATING
A	2
B	4
C	6
D	8
E	10
F	12
G	14
H	16
J	18
L	20
M	22
N	24

Truck Tire Tread Depth Conversion Table to Percent Of Wear:

Original Tire Tread Depths in 32nds

Tread Remaining	32nd	12	13	14	15	16	17	18	19	20	21	22	23	24	25	26	27	28	29	30	32	37	38	39	40	41	32nd	Tread Remaining		
	2/32	100%	100%	100%	100%	100%	100%	100%	100%	100%	100%	100%	100%	100%	100%	100%	100%	100%	100%	100%	100%	100%	100%	100%	100%	100%	2/32			
	3/32	90	91	92	92	93	93	94	94	94	95	95	95	95	96	96	96	96	96	96	97	97	97	97	97	97	97	3/32		
	4/32	80	82	83	85	86	87	88	88	89	89	90	90	91	91	92	92	92	93	93	93	94	94	94	95	95	95	4/32		
	5/32	70	73	75	77	79	80	81	82	83	84	85	86	86	87	88	88	88	89	89	90	91	92	92	92	92	92	5/32		
	6/32	60	64	67	69	71	73	75	76	78	79	80	81	82	83	83	84	85	85	86	87	89	89	89	89	89	90	6/32		
	7/32	50	55	58	62	64	67	69	71	72	74	75	76	77	78	79	80	81	81	82	83	86	86	86	86	87	87	7/32		
	8/32	40	45	50	54	57	60	63	65	67	68	70	71	73	74	75	76	77	78	79	80	83	83	84	84	85	85	8/32		
	9/32	30	36	42	46	50	53	56	59	61	63	65	67	68	70	71	72	73	74	75	77	80	81	81	82	82	82	9/32		
	10/32	20	27	33	38	43	47	50	53	56	58	60	62	64	65	67	68	69	70	71	73	77	78	78	79	79	79	10/32		
	11/32	10	18	25	31	36	40	44	47	50	53	55	57	59	61	63	64	65	67	68	70	74	75	76	76	77	77	11/32		
	12/32	0	9	17	23	29	33	38	41	44	47	50	52	54	57	58	60	62	63	64	67	71	72	73	74	74	74	12/32		
	13/32		0	8	15	21	27	33	35	39	42	45	45	50	52	54	56	58	59	61	63	69	69	70	71	72	72	13/32		
	14/32			0	8	14	20	25	29	33	37	40	43	45	48	50	52	54	56	57	60	66	67	68	68	69	69	14/32		
	15/32				0	7	13	19	24	28	32	35	38	41	43	46	48	50	52	54	57	63	64	65	66	67	67	15/32		
	16/32					0	6	13	18	22	26	30	33	36	39	42	44	46	48	50	53	60	61	62	63	64	64	16/32		
	17/32						0	6	12	17	21	25	29	32	35	38	40	42	44	46	50	57	58	59	61	62	62	17/32		
	18/32							0	6	11	16	20	24	27	30	33	36	39	41	43	47	54	56	57	58	59	59	18/32		
	19/32								0	6	11	15	19	23	26	29	32	35	37	39	43	51	53	54	55	56	56	19/32		
	20/32									0	5	10	14	18	22	25	28	31	33	36	40	49	50	51	53	54	54	20/32		
	21/32										0	5	10	14	17	21	24	27	30	32	37	46	47	49	50	51	51	21/32		
	22/32											0	5	5	13	17	20	23	26	29	33	43	44	46	47	49	49	22/32		
	23/32												0	9	9	13	16	19	22	25	30	40	42	43	45	46	46	23/32		
	24/32													0	4	8	12	15	19	21	27	37	39	41	42	44	44	24/32		
	25/32														0	4	8	12	15	18	23	34	36	38	39	41	41	25/32		
	26/32															0	4	8	11	14	21	31	33	35	37	38	38	26/32		
	27/32																0	4	7	11	17	29	31	32	34	36	36	27/32		
	28/32																	0	4	7	13	26	28	30	32	33	33	28/32		
	29/32																		0	4	10	23	25	27	29	31	29/32			
	30/32																				0	7	20	22	24	26	28	30/32		
	31/32																					3	17	19	22	24	26	31/32		
	32/32																					0	14	17	19	21	23	32/32		
	33/32																						11	14	16	18	21	33/32		
	34/32																						9	11	14	16	18	34/32		
	35/32																						6	8	11	13	15	35/32		
	36/32																						3	6	8	11	13	36/32		
	37/32																						0	3	5	8	10	37/32		
	38/32																							0	3	5	8	38/32		
	39/32																								0	3	5	39/32		
	40/32																									0	3	40/32		
	41/32																										0	41/32		

SAFETY WARNING

SERIOUS INJURY MAY RESULT FROM:

Explosion of tire/rim assembly due to improper mounting - use safety cage and clip on extension air hose. Only specially trained persons should mount tires.

Tire failure due to misapplication/improper inflation/overloading - follow tire manufacturer's instructions. Check inflation pressure frequently with gauge.

A tire must always match the diameter requirements of the rim to which it is being mounted. For example, a 16 inch tire must always be mounted on a 16 inch rim. Also, when replacing the truck type radial tires, use only wheels approved for radial tires.

Retread Casing Fitment Guide

Tread Width Followed By Tire Sizes

150	185 (continued)	205 (continued)	215 (continued)	225 (continued)	245 (continued)	390
9R22.5	245/70R19.5	225/70R19.5	225/70R19.5	12.00R24	12.00R24	445/50R22.5
215/85R16	265/70R19.5	225/75R16	245/70R19.5	11R24.5	11R22.5	455/55R22.5
160	255/70R22.5	235/75R17.5	265/70R19.5	12R24.5	11R24.5	400
215/85R16	10R17.5	235/85R16	285/70R19.5	230	250	445/50R22.5
225/75R16	9R22.5	245/70R17.5	255/70R22.5	275/80R22.5	365/80R20	455/55R22.5
235/85R16	10R22.5	245/70R19.5	275/70R22.5	295/75R22.5	305/70R22.5	410
215/75R17.5	195	245/75R16	275/80R22.5	285/75R24.5	315/80R22.5	445/50R22.5
235/75R17.5	215/85R16	255/70R22.5	295/75R22.5	11R22.5	12.00R24	455/55R22.5
10R17.5	225/75R16	265/70R19.5	285/75R24.5	12R22.5	260	
9R22.5	235/85R16	275/70R22.5	10R22.5	12.00R24	315/80R22.5	
170	245/75R16	275/80R22.5	11R22.5	11R24.5	305/75R24.5	
215/85R16	215/75R17.5	285/70R19.5	12R22.5	12R24.5	270	
225/75R16	235/75R17.5	285/75R24.5	12.00R24	235	315/80R22.5	
235/85R16	225/70R19.5	295/75R22.5	11R24.5	275/80R22.5	305/75R24.5	
215/75R17.5	245/70R19.5	245/75R22.5	12R24.5	295/75R22.5	280	
235/75R17.5	265/70R19.5	265/75R22.5	220	285/75R24.5	315/80R22.5	
225/70R19.5	255/70R22.5	210	235/75R17.5	11R22.5	290	
10R17.5	10R17.5	225/75R16	245/70R17.5	12R22.5	365/80R20	
9R22.5	9R22.5	235/85R16	245/70R19.5	12.00R24	385/65R22.5	
10R22.5	10R22.5	245/75R16	265/70R19.5	11R24.5	320	
180	200	235/75R17.5	285/70R19.5	12R24.5	365/80R20	
215/85R16	225/75R16	245/70R17.5	255/70R22.5	240	385/65R22.5	
225/75R16	235/85R16	225/70R19.5	275/70R22.5	275/80R22.5	425/65R22.5	
235/85R16	245/75R16	245/70R19.5	275/80R22.5	295/75R22.5	340	
245/75R16	215/75R17.5	265/70R19.5	295/75R22.5	295/80R22.5	18R19.5	
215/75R17.5	235/75R17.5	285/70R19.5	295/80R22.5	305/70R22.5	18R22.5	
235/75R17.5	245/70R17.5	255/70R22.5	285/75R24.5	315/80R22.5	445/65R22.5	
225/70R19.5	225/70R19.5	275/70R22.5	10R22.5	285/75R24.5	445/65R19.5	
245/70R19.5	245/70R19.5	275/80R22.5	11R22.5	11R22.5	445/50R22.5	
255/70R22.5	265/70R19.5	295/75R22.5	12R22.5	12R22.5	425/65R22.5	
10R17.5	255/70R22.5	285/75R24.5	12.00R24	12.00R24	350	
9R22.5	10R17.5	10R22.5	11R24.5	11R24.5	18R19.5	
10R22.5	10R22.5	11R22.5	12R24.5	12R24.5	18R22.5	
185	12.00R24	12R22.5	225	245	445/65R22.5	
215/85R16	205	12.00R24	285/70R19.5	295/75R22.5	445/65R19.5	
225/75R16	10R22.5	11R24.5	275/80R22.5	275/80R22.5	445/50R22.5	
235/85R16	11R22.5	12R24.5	295/75R22.5	285/75R24.5	425/65R22.5	
245/75R16	11R24.5	215	295/80R22.5	295/80R22.5	360	
215/75R17.5	12.00R24	235/85R16	285/75R24.5	365/80R20	445/65R22.5	
235/75R17.5	12R22.5	235/75R17.5	11R22.5	305/70R22.5	380	
225/70R19.5	12R24.5	245/70R17.5	12R22.5	315/80R22.5	445/65R22.5	

***Not a technical recommendation or guide.** For use as sales information only. Please consult your local authorized ContiLifeCycle dealer for technical specifications.

Safety Warnings

Tire Demounting And Mounting Safety Precautions



SAFETY WARNING

SERIOUS INJURY OR DEATH MAY RESULT FROM:







EXPLOSION OF TIRE RIM ASSEMBLY DUE TO IMPROPER MOUNTING - USE SAFETY CAGE & CLIP-ON EXTENSION AIR HOSE. ONLY SPECIALLY TRAINED PERSONS SHOULD MOUNT TIRES.



WARNING

Tire and wheel servicing can be dangerous, and should be done by trained personnel using proper tool and procedures and safety precautions in the RMA's "Demounting and Mounting Procedures for Trucks/Bus Tires" and "Inspection procedures for identification of potential zipper ruptures in steel cord radial medium and light truck tires" charts and service bulletins.

Failure to comply with these procedures may result in faulty positioning of the tire and/or rim parts, and cause the assembly to burst with explosive force, sufficient to cause serious injury or death. Never mount or use damaged tires or rims.

MISAPPLICATION/IMPROPER INFLATION/OVERLOADING SAFETY WARNINGS



WARNING

There is danger of serious injury or death if a tire of one bead diameter is installed on a rim or wheel of a different rim diameter.

Re-assembly and inflation of mismatched parts can result in serious injury or death. Just because parts come in together does not mean they belong together. Check for proper matching of all rim parts before putting any parts together.

Always replace a tire of exactly the same bead diameter designation and suffix letters.

For example: A 16" tire goes on a 16" rim. Never mount a 16" tire on a 16.1" or 16.5" rim. A 16.1" tire goes on a 16.1" Never mount a 16.1" tire on a 16" or 16.5" rim. A 16.5" tire goes on 16.5 " rim. Never mount a 16.5" tire on a 16" or 16.1" rim.

While it is possible to pass a 16" diameter tire over the lip or flange of a 16.1" or 16.5" size diameter rim, it cannot be inflated enough to position itself against the rim flange. If an attempt is made to seat the tire bead by inflating, the tire bead will break with explosive force and could cause serious injury or death.

Rims of different diameters and tapers cannot be interchanged. The following diagram illustrates the difference between rims of two different tapers and diameters.

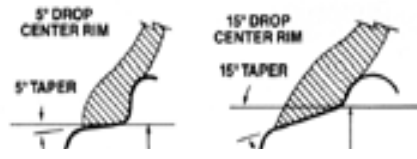

The following diagram shows how beads of a 16" tire will not seat on a 16.5" rim. The beads cannot be forced out against the rim flanges by using more air pressure because this will break the beads and the tire will explode with force sufficient to cause serious injury or death.



Never assemble a tire and rim unless you have positively identified and correctly matched the parts.

Safety Warnings

Tire Demounting And Mounting Safety Precautions

WARNING

NEVER inflate beyond 40 pounds pressure to seat beads.
NEVER stand, lean or reach over the assembly during inflation.
Inspect both sides of the tire to be sure that the beads are evenly seated. If tire is mounted on a machine that does not have a positive lock-down device to hold the wheel, inflation should be done on a safety cage. If both beads are not properly seated when pressure reaches 40 pounds air pressure, completely deflate the assembly, reposition the tire and/or tube on the rim, re-lubricate and reinflate. Inflating beyond 40 pounds air pressure when trying to seat the beads is a DANGEROUS PRACTICE that may break a tire bead (or even the rim) with explosive force, possibly resulting in serious injury or death. After the beads are fully seated, pressure may be increased above 40 psi to operating pressures, not to exceed the maximum labeled on the tire sidewall.

WARNING

Permanent tire damage due to under inflation and/or overloading cannot always be detected. Any tire known or suspected to have been run at 80% or less of normal operating inflation pressure and/or overloaded, could possibly have permanent structural damage (steel cord fatigue). Ply cords weakened by under inflation and/or overloading may break one after another, until a rupture occurs in the upper sidewall with accompanying instantaneous air loss and explosive force. This can result in serious injury or death.

Any tire of having been operated and under inflated and/or overloaded must be approached with caution. Completely deflate the tire by removing the valve core before removing the tire/rim/wheel assembly from the vehicle. After removing from the vehicle, clearly identify the tire so it will not be reinflated **until carefully inspected by a trained technician** to determine the cause of under inflation, as well as any tire damage resulting from under inflation and/or overloading.

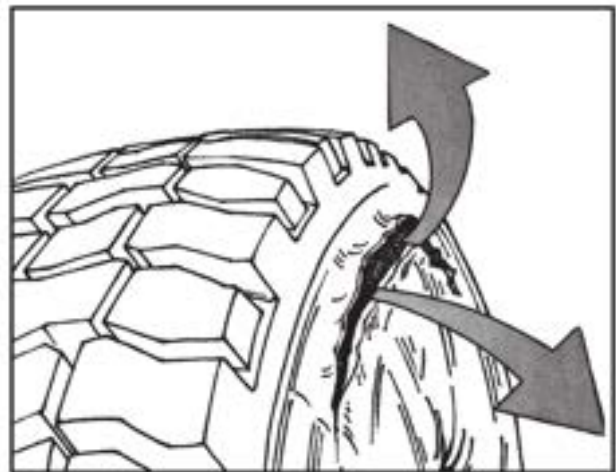

WARNING

The use of any flammable material during tire servicing is absolutely prohibited. Use of starting fluid ether, gasoline, or any other flammable material to lubricate, seal or seat the beads of a tubeless tire can cause the tire to explode or can cause the explosive separation of the tire/rim assembly resulting in serious injury or death.

This practice may also result in undetected damage to the tire or rim that could result in failure of the tire in service.

Safety Warnings

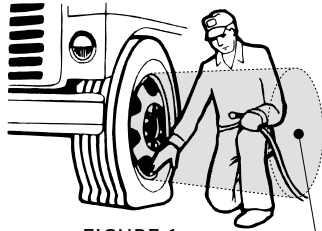

FIGURE 1

STAY OUT OF THE TRAJECTORY AS INDICATED BY SHADED AREA

Note: Under some circumstances, the trajectory may deviate from its expected path.

Always deflate tires before handling. Inflate only in safety cage.



FIGURE 2

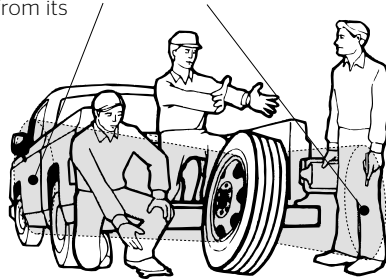

FIGURE 3

TRAJECTORY

The air pressure contained in a tire is dangerous. The sudden release of this pressure by a tire blow-out or side ring separation can cause serious injury or death. Stay out of the trajectory as indicated by shaded area. When installing the tire/rim assembly on the vehicle, it will be impossible to stay out of the trajectory; however, at all other time you and all others must stay out of the trajectory.



WARNING

Tire explosions can cause death or personal injury or property damage.

Excessive speed in a free-running, unloaded tire can cause it to “explode” from extreme centrifugal force.



WARNING

When mounting dual disc wheels on a vehicle, be sure to carefully check and retighten or re-torque inner cap nuts before mounting the outer wheel. In demounting the outer wheel, there is a possibility that the inner cap nuts may have been loosened accidentally.

NEVER rework, weld, heat, or braze the tire/wheel/rim. Heating the rim of tire/wheel/rim. Heating the rim of tire/wheel/rim assembly can cause a tire to explode, causing serious injury or death,

NEVER hammer, strike or pry any type of tire/rim assembly while the tire contains inflation pressure. Do not attempt to seat any part while the tire contains any inflation pressure. This could result in serious injury.

Regrooving

Continental, General Tire, AmeriSteel, and Euzkadi brand truck tires that have “REGROOVABLE” molded on the sidewall may be regrooved. After regrooving, it is required that 3/32” of under tread remains to cover the top ply. It is the responsibility of the regroover to assure that all Federal Regulations are met. For further clarification, see Code of Federal Regulations: Title 49, Transportation; Parts 569 and 393.75.



The Future in Motion

1830 MacMillan Park Drive
Fort Mill, S.C. 29707

Check here if Return to Stock Tires ONLY

DO NOT PAY FROM THIS DOCUMENT
AN INVOICE WILL BE SENT FROM CONTINENTAL TIRE THE AMERICAS, LLC.

DELIVERY RECEIPT

D9

DATE DELIVERED	CUST ORDER DATE	PURCHASE ORDER NUMBER AND/OR AUTHORIZATION NUMBER
----------------	-----------------	---

NATIONAL ACCOUNT AND/OR FLEET BILLING REQUIREMENTS:		
ALWAYS SHOW CUSTOMER INFORMATION. REFER TO NAT'L ACCOUNT DIRECTORY		
RELEASE NO./FLEET NO.	ID CARD NO.	VEHICLE NO.
WHEEL POSITION	AUTHORIZATION NO.	
LICENSE & STATE	ODOMETER/HUBOMETER	VEHICLE MAKE/YEAR
17 DIGIT VIN #: _____		

DELIVERED BY- DEALER ACCOUNT NUMBER	
ACCOUNT NO.	ASSOCIATE DEALER
NAME	
ADDRESS	
CITY, STATE, ZIP	

IMPORTANT

Dealer must check
(✓) ONE ONLY for
Continental Tire
the Americas, LLC.
to correctly apply Sales Tax.



3.
Tires delivered
to this location

OR



1. Tires delivered
to this location



2. Tires delivered
to this location

OR

4.

If neither, enter City, County, and
State tires shipped to or picked up at:

STREET	
CITY	
COUNTY	ZIPCODE
STATE	

SHIPPED TO/DELIVERED TO (COMPANY NAME)		SOLD TO/BILLED TO (WHERE INVOICE IS TO BE SENT)	
CTA ACCOUNT NUMBER (REQUIRED FOR CAR DEALERS)			
CUSTOMER NAME		NAME	
STREET ADDRESS		STREET ADDRESS	
CITY	STATE	ZIP	CITY STATE ZIP
TIRE/SERVICE ACCEPTED BY: (PRINT)	COMPANY TELEPHONE	AUTHORITY	
	() - - - - -	WHEN DELIVERING TO CUSTOMERS OF OTHER DEALERS OR NEEDING FLEET MANAGER APPROVAL SHOW AUTHORITY OBTAINED	
TIRE/SERVICE ACCEPTED BY: SIGNATURE (ACKNOWLEDGE RECEIPT OF PRODUCT-REQUIRED)		PHONE <input type="checkbox"/>	NAME:

MERCHANDISE

INSTRUCTIONS	QTY.	SIZE	PLY	DESCRIPTION	PRODUCT CODE OR ARTICLE NO.	INPUT PRICE PER UNIT WHEN ASKED FOR
SAFETY SERVICE: SHOW MAKE OF VEHICLE, DESCRIPTION, PRICE OF SERVICE IF NOT NOTED IN SERVICE PRICE LIST AND PRODUCT CODE NUMBER						
WRITE COMPLETE DESCRIPTION ON ALL MERCHANDISE DELIVERED						
MAIL ORIGINAL DELIVERY RECEIPT PART TO CONTINENTAL TIRE THE AMERICAS, LLC. NATIONAL ACCOUNTS, 1830 MACMILLAN PARK DRIVE, FORTMILL, SC 29707						
< >				COMMERCIAL TRUCK CASING CREDIT	2023010000	

WARRANTY INFORMATION

For Commercial Vehicle Tires Only

One of the largest automotive suppliers and tire manufacturers in the world, Continental develops pioneering technologies to make fleets safer, more efficient, and more connected. With innovative tire technology and digital fleet solutions, Continental optimizes tire lifecycle management to deliver the lowest overall driving cost.

For the most up-to-date warranty information, please visit:

Visit www.continental-truck.com/truck/warranty



Limited Warranty & Adjustment Policy



ContiTread™



AMERI★STEEL



Continental Truck and Bus Tires
www.continental-truck.com

ContiLink

Your Connection to Dealer Support & Resources

Standard Claims Processing

If you can name it, you can claim it... pricing, shipping, sales tax, advertising and waste fee claims are just a few that have the ability to process through ContiLink.

Order Tracking

Whether you need to check product availability, place an order, track shipping or monitor backorder reports, ContiLink has your needs covered.

Marketing Needs

As a Continental dealer, you can purchase sales literature and point-of-sale material for your showroom anytime, or download digital copies in PDF format. Simply log into ContiLink and click on the Marketing Suite banner.

National Accounts & Government Claims

Through the National Accounts and Government Claims section of ContiLink, you can submit delivery receipts, review customer requirements, submit government claims and more.

Financial

Through ContiLink's Financial feature, you have the ability to view real-time debits/credits on open items and print, email or save copies of invoices, statements and credit memos.

Emergency Road Service Tracking

With detailed reporting from Continental's TrukFix emergency road service program, you can see at a glance your acceptance rates for calls and opportunities to increase service revenue with Continental.

ContiACADEMY

Gain access to ContiAcademy, our virtual training platform to learn about Continental products, solutions, and live training opportunities.

LOG ON TO WWW.CONTILINK.COM TODAY!

Administration

ContiLink gives Dealers the flexibility to update their profiles. Keep your dealer location information up to date, and edit users and user information as needed.

Digital Downloads

Need instant access to Continental resources? Visit the Marketing section of the ContiLink site and download digital copies of the literature you need, including your Dealer Marketing Program book.

Live Chat

Chat with a Truck Tires Inside Sales representative or a National Account specialist to check your orders or if you have a question about a delivery receipt. Get the information you need when you need it.

Dealer Marketing Suite

A one-stop shop for all your marketing needs.



Marketing Suite Features:

- » Latest literature for all brands
- » Point-of-sale and promotional items
- » Custom flyers for your event
- » All forms including D-9 and Warranty

THE DEALER MARKETING SUITE OFFERS FREE AND PAID SERVICES:

- » Download PDF documents for free
- » Order printed literature, forms, and promo items with a credit card

HOW TO ACCESS:

1. Log into ContiLink (www.contilink.com)
2. Scroll down until you see the “Dealer Marketing Suite”
3. Click on “Read More”
4. The Dealer Marketing Suite will open and allow you to browse items!

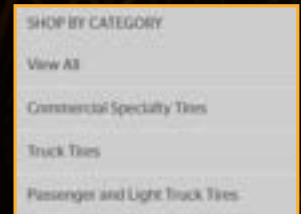

First Time Login:

1. Log into ContiLink (www.contilink.com)
2. Scroll down until you see the “Dealer Marketing Suite”
3. Click on “Read More”
4. You will receive a message that your Dealer Marketing Suite account has been requested. The account will be created within a few hours.

Don't forget! The ContiTireDrive app gives you access to PDF literature for all brands on your mobile device.



Available for iOS and Android



HorsePower UnTamed

Continental's Loyalty Rewards Program

HORSEPOWER

untamed

horsepowerrewards.com

Enroll Today! Contact your Continental representative to learn more.



Some Sweet Rewards For You

Sell tires. Collect points. Earn rewards. Repeat. Choose from an extensive collection of name-brand apparel, cash gift cards and more.



We Value Your Loyalty

Sell a certain number of tires and you will receive a gift and a recognition plaque. We appreciate your loyalty and now allow us to return the favor.



Earning Points is Easy

Once enrolled, you'll have 45 days from the end of the month to submit tire sales. Simply login and use the Power Page to upload invoices and submit claims. Points will be instantly deposited into your account upon claim approval.

HorsePower Untamed is available by invitation only to a select group of individual salespeople selling to fleets and users directly. No wholesale or intercompany transfers are permitted in this program. No sales may be aggregated; but must be solely the reporting participant's sales. Any tax liability is the individual's responsibility. A valid individual W-9 tax form including your SSN (not a company tax ID) must be on file with Continental to redeem in the program. As well as TD1 form for Canadian participants. Aggregation of points over groups of salesman and/or tax information that is of a business nature will not be permitted. Owners and dealer principals are not eligible to participate in this program.



Continental Tire the Americas, LLC
1830 MacMillan Park Drive
Fort Mill, SC 29707
Phone: 704-583-3900

Technical Customer Services & Warranty
3000 Continental Parkway
Clinton, MS 39056
Phone: 800-726-7113
TI_CQ_SM_help.trucktires@continental.com

Original Equipment Sales
800-776-2022

Commercial Specialty Tires
877-235-0102

INSIDE SALES / U.S.
800-450-4028 East
800-450-3187 West

